

Communication Mechanism and Algorithm of Composite Location Analysis of Emergency Communication based on Rail

Yong Jiang¹, Xiaolin Zhong^{1,*}, Yong Guo¹ and Meixia Duan²

Abstract: The emergency communication system based on rail is an unconventional emergency communication mode, it is a complement equipment for that conventional communication system can't work while tunnel mine accident occurs. Medium of transmission channel is the widely existing rail in the tunnel. In this paper we analyzed the characteristics of the rail transmission channel, verified the feasibility that information is transmitted by vibration signal in rail, we proposed the realization plan of the system. Communication protocol and processing mechanism suitable for rail transmission are designed according to the characteristics of channel bandwidth and low data transmission. Information communication with low bit rate and low bit error is realized in the communication simulation model. In the simplified model, we realized to transmit recognition speech information, and the error rate of the key text information is low to accept. The most concerned problem of personnel location in the mine disaster rescue is proposed, the composite algorithm is based on the model of signal amplitude attenuation, key node information and data frame transmission delay. Location information of hitting point can be achieved within the simplified model of the experiment. Furthermore, we discuss the characteristics of vibration signals passing through different channels.

Keywords: Emergency communication, elastic wave, attenuation, composite locating algorithm, rfc2544.

1 Introduction

Geological phenomena of fracture, fault, fold is one of the main reasons causing the mine accident. Unpredictable geological condition is the feature of the tunnel construction. Before construction, it is often not possible to accurately grasp the geological conditions of surrounding rock, change, groundwater, karst, and so on [Sobolev, Sobolev, Kuzmin et al. (2011)]. The form of local fracture zone, coal strata, and mining destroys the fracture zone of stress equilibrium, roof caving accidents is easy to occur. The roof accident is the main potential danger of the mine tunnel construction [Karlinski, Ptak, Dzialak et al. (2016)]. The serious or slight mine disaster occurred in the world every year. Since environment of coal mining industry is relatively complicated and vary, it leads to all sorts of mine disaster occurred frequency. Especially, China is a mine accident prone

¹ College of geophysics, Chengdu University of Technology, Chengdu, 610059, China.

² College of Information Engineering, North China University of Water Resources and Electric Power, Zhengzhou, 450045, China.

* Corresponding Author: Xiaolin Zhong. Email: duanmeixia@ncwu.edu.cn.

country, according to a reliable survey, miner industry is the rank first industry nationwide with high occupational injury and fatality rate in China. By the end of December 7, 2016, just the death toll in coal mine industry is up to 198 or more. Fig. 1 shows the number of victims of coal mine disaster of china in 2016. Data source: China Coal Education Network.

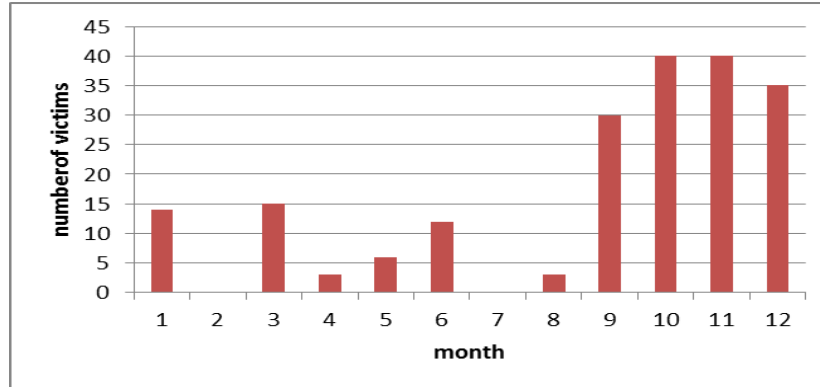

Figure 1: Victims distribute chart

While mine collapse occurs, it is accompanied by other hazards. Such as the alleyway is blocked, communication is interrupted. Some workers in the pit cannot escape in time, the air is insufficient in the confined space, and harmful gas content is high. These situations threat to the safety of personnel trapped seriously [Wang, Cheng, Wang et al. (2015); Wang, Tu, Yuan et al. (2013); Kilinc, Monaghan and Powell (2014)].

The best time for rescue is 72 h after the occurrence of geological disasters. Communication with the trapped survivors timely, quickly get trapped information help rescue team to launch rescue plan.

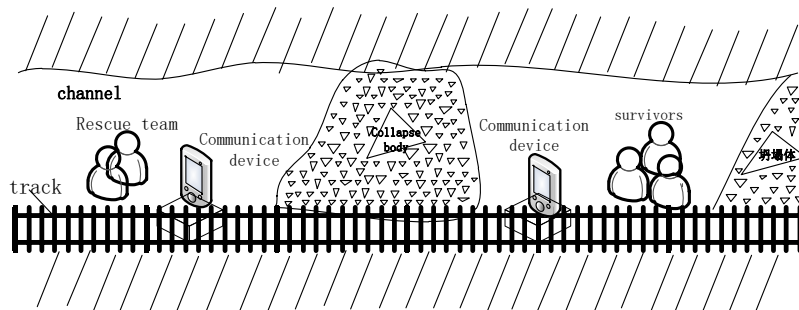

Figure 2: Survivors in mine diagram

Successful communication is critical during the emergency system. The rapid and reliable establishment of emergency communication between trapped persons and rescue team is an important prerequisite for effective rescue, which is of great significance to improve the effectiveness of post disaster relief.

The emergency communication is a special communication mechanism for responding to emergency. That is aimed at reconstructing channel of deterioration of external

environment, damage of the facilities and infrastructure. The technology comprises a variety of communication technology, cable, wireless, satellite, hybrid communication, and special communication. Application of technology is closely related to disaster scene environment.

With the rapid development of wireless technology, underground wireless communication technology is also developing rapidly. Underground wireless communication technology has made contributions to safety, modern production and management of coal mines. The development of underground wireless communication has experienced several generations, from power line carrier communication, intermediate frequency communication, leakage communication, to ultra low frequency communication, wireless mobile communication [Dashti, Bray, Reilly et al. (2014); Bernas and Placzek (2015)].

The people can investigate seismic damage condition quickly with the emergency communication system based on smartphone [Han, Zhao, Yu et al. (2016)].

A method based on cell phone and information technology to measure ground motion intensity parameters can be applied [Reina, Ruiz, Ciobanu et al. (2016)].

Ultra low frequency wireless communication is based on the earth as the transmission medium, so that the electromagnetic waves through the earth directly to achieve communication with the underground. The outstanding advantages are due to the transmission medium is the earth, the accidents, such as roof collapse, exploration, geological disaster can't breakdown the transmission channel, while the disadvantage is that flexibility is poor and vulnerable to interference of low frequency signal.

There are several disadvantages for underground wireless emergency communication when accident occurs. Firstly since the collapse of tunnel, wireless signal cannot penetrate the barrier. Secondly since the complex underground environment, the interference of low frequency electromagnetic is large, SNR of wireless signal is low.

The cable communication is still the backbone network underground communication now, as it is the main frame of communication under normal working conditions. When accident occurred, the cable and relay equipment probably are damaged, broken, short circuited. The cable communication system usually paralyzed completely when accident occurred.

Mine catastrophes happened in history have shown that conventional methods, wire-line or wireless communication, are hard to work normal under extreme circumstance, such as roof falls, fires.

In response to the distribution of rail in mine, the authors propose an innovative communication scheme based on rail track, a technological approach for emergency communication at the sense of disaster. This system is a good complement communication mode while traditional communication is invalidate, such as cable or wireless communication.

Our main contributions lies in proposing a communication frame based on vibration wave transmission in rail, designing the communicate protocol, furthermore, proposing a composite algorithm of location for the trapped survivors.

2 Method and implementation

When the mine accident occurs, the mine shafts may be blocked and collapse, even more explosion occurred, explosion can damage the equipment block, interrupt the channel. The communication cable is easily affected by the extrusion deformation and fracture, short circuit. Relay equipment is damaged. Above all the cases could lead to communication system paralysis.

The disaster can destroy the communication channel easily, so the people have to find a special channel used for transmit rescue information. This channel media should be general and could not be broken down easily in the disaster, and this media should be easy to find and to be used, will not increase the redundant use difficulty, trapped personnel can quickly and effectively contact with the outside world. These facilities are not easy broken down completely.

Rail is the core transport equipment in mine, and there are a large number of rails in the coal mining tunnel. The underground rail can be used to connect the working surface with other parts of the underground, and not easy to damage. The metal track maybe distorted or pulled up in the event of accident, but it is difficult to collapse, so the rail track become the transmit channel is possible in practice. The track could not be completely damaged in tunnel construction accident.

When the survivor taps the rail track periodically, vibration signal can transmit to the distant places within the track. Therefore, using metal track as the carrier material, by tapping the regular, complex signal can be transform into vibration signal, then vibration signal propagates along the metal conductor, receiver captures signal with vibration detection sensor, so as we can achieve the purpose of communication with survivors.

Isotropic medium is almost the best material fitting for elastic wave transmitting. Vibration signal is also very difficult to be interfered in the underground complex environment.

Here, rail is simplified as homogeneous, isotropic solid material. According to the relationship between elastic medium displacements, stress and strain, we can derive elastic wave equation set (1) in homogeneous and isotropic solids with the generalized Hooke's law, it is as follows.

$$\begin{cases} \rho \frac{\partial^2 u_x}{\partial t^2} = (\lambda + \mu) \frac{\partial \nabla}{\partial x} + \mu \nabla^2 u_x \\ \rho \frac{\partial^2 u_y}{\partial t^2} = (\lambda + \mu) \frac{\partial \nabla}{\partial y} + \mu \nabla^2 u_y \\ \rho \frac{\partial^2 u_z}{\partial t^2} = (\lambda + \mu) \frac{\partial \nabla}{\partial z} + \mu \nabla^2 u_z \end{cases} \quad (1)$$

Where ρ is the solid medium density, λ and μ is the lame constant.

In the case of ignoring the external influence factors, the internal medium of the rail channel is considered to be uniform and isotropic, and the elastic wave equation in the solid is transmitted by the sound wave in the rail.

From equation set (1), we can get the velocity of Transverse Wave c_2 and Longitudinal Wave c_1 . It is as follows

$$\begin{cases} c_1 = \sqrt{\frac{\lambda + 2\mu}{\rho}} = \sqrt{\frac{E(1-\sigma)}{(1+\sigma)(1-2\sigma)\rho}} \\ c_2 = \sqrt{\frac{\mu}{\rho}} = \sqrt{\frac{E}{2(1+\sigma)\rho}} \end{cases} \quad (2)$$

The parameters of vibration signal are partially determined by the amplitude and frequency of vibration wave, partially affected by the property of channel, such as material, length, shape. In the rail track, we omit the vectors at y, z axis. The vibration signal can be expressed as follows derived from equation set (1).

$$x_c(t) = A^{-\epsilon t} \sin \omega t + n(t) \quad (3)$$

We have captured the wave in time area about pulse impact signal to rail, the wave is as Fig. 3.

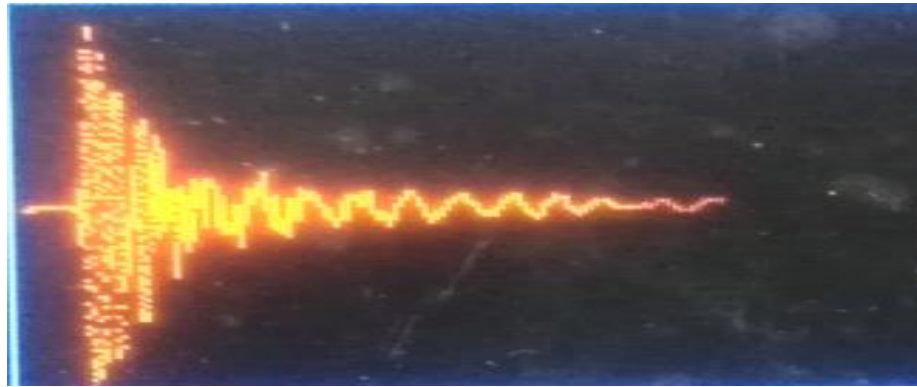

Figure 3: Wave of once knock

There are three main factors affecting that the vibration signal transmits at the disaster site, the material or structure of rail track, the buried objects adhere to track, and the branch in the rail.

The attenuation of rail to the vibration signal is mainly due to the absorption and attenuation of the heat flow generated by the rigid collision between the steel atoms. The equation is as follow:

$$A = \frac{2\pi f^2}{\rho v^3} \cdot \left[\frac{k_h}{C_v} \cdot \left(\frac{E^b - E^\theta}{E\theta} \right) \right] (NP / m) \quad (4)$$

f is the frequency, ρ is the density, v is the longitudinal wave velocity, k_h is the heat conduction coefficient, C_v is the constant volume specific heat, E is the corresponding medium elasticity coefficient, σ is the adiabatic value, θ is the constant temperature value.

Vibration wave radiates energy while wave across boundary of rail, it results in the

attenuation of received signal amplitude. When it passes the buried object, the vibration radiation diagram of different media is as follows.

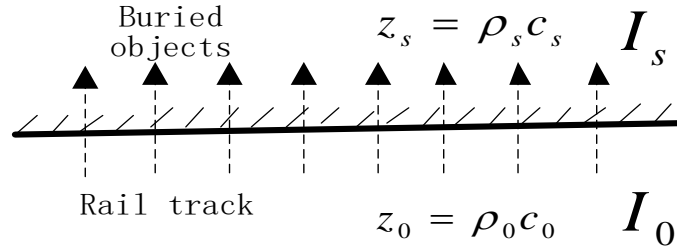

Figure 4: Vibration radiation diagram

z_0 is rail impedance, I_0 vibration intensity, z_s is buried impedance, sound pressure $P = \sqrt{2\rho cI}$, so sound pressure difference between the two sides of the rail is as follows:

$$\Delta P = P_0 - P_s = \sqrt{2\rho_0 c_0 I_0} - \sqrt{2\rho_s c_s I_s} \tag{5}$$

Further following equation is obtained

$$\sigma = 20 \log(\Delta P) \tag{6}$$

σ is unit attenuation factor.

The attenuation factor of the vibration signal passing through a buried rail is $\lambda = 2\pi r l \sigma$. The gap between the rails, the branch can weaken vibration signal, and the details of attenuation can be tested through experiments. Field tests show that the attenuation of vibration waves through I and II type slits is small, and the attenuation of vibration waves is obvious through the fork road, as shown in Fig. 5 and Fig. 6.



Figure 5: Gap and branch of rail track

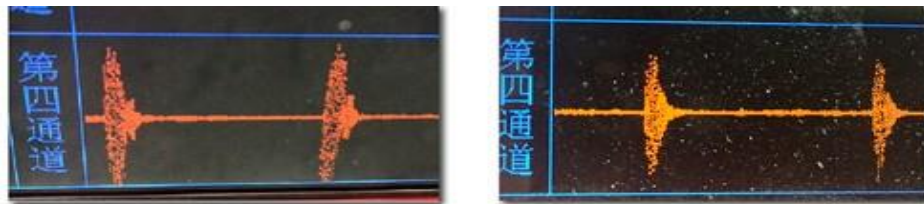

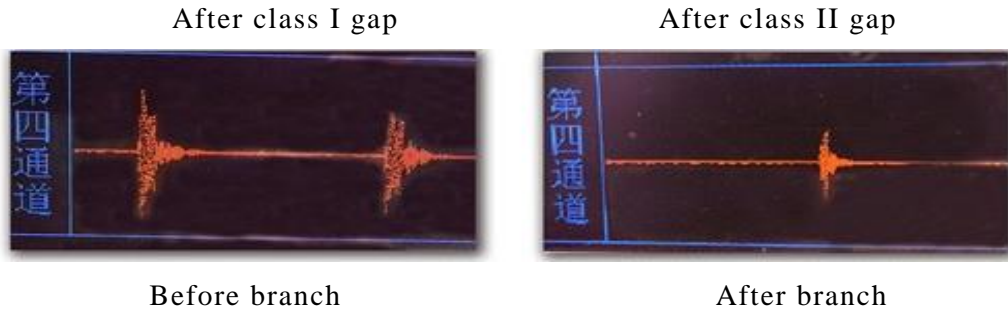

Figure 6: Vibration wave after gap or branch of rail track

The attenuation of vibration signal in the solid is very small, thus vibration wave can be propagated far away in solid. The propagation speed of vibration wave is about 5000m/s. The elastic wave attenuates very much in the air. The velocity of acoustic wave in air is slow (about 300 m/s), and the attenuation is very quickly. As a point source, the attenuation of vibration in the air is caused by the distance. And the equation of attenuation is as follow:

$$A_{div} = 10 \log\left(\frac{1}{4 * \pi * R^2}\right) \quad (7)$$

According to the actual statistics, the attenuation of air transmission is about 3-6 dB which is caused by the increasing interface distance because of the rail bending and pulling.

The vibration transverse wave is interacting with the surrounding medium and attenuates the radiant energy, while the longitudinal wave has only the lowest order wave and the lateral displacement is small, and the energy attenuation is slow. Shear wave energy attenuation is serious and longitudinal wave attenuation is small in rail. So this system uses longitudinal wave to transmit the signal, and the system employs special exciting component and vibration sensor at the transceiver, making P-wave as the transmission signal in the emergency system.

We have done many practices in this item, simulation of vibration equipment knocked rail at the distance of 50 m, in the shooting, B point, C point, the vibration signal is detected at the receiving point, and the receiving instrument captures waveform data to analyze.

From analyzing the data, we know that rail track is good channel for vibration signal transmitting, the attenuation of elastic wave is small in rail channel. Even through the bifurcation and fracture boundary, the original vibration signal can still be clearly identified. Track can be used as vibration medium for connecting trapped persons and rescue team while gallery is blocked.



Figure 7: Knocked point field site

The details of data are as follow:

Table 1: Transmission distance in different medium

Medium	Hammer (kg)	Exciting fore (N)	Distance (m)
Steel	0.5	5 N	202
Steel	1	10 N	210
Masonry	1	10 N	180
Masonry	2	20 N	217

We established a new emergency communication system based on vibration wave which transmits in the steel track, rescue team can communicate with the trapped person through this system. The trapped personnel could find the nearest communication device based on vibration signal, report the condition on the scene by voice, text, or default preset.

The random, irregular tap behavior can just transmit simple information, communication standards must be abided for transmission of complex information. A whole set of protocol is necessary for communication system, from mac layer, link layer to application layer.

To adapt the low bandwidth characteristics of transmission channel, FSK mode is used as the basic communication modulation mode, source information is pre-coded in advance, Speech signal is low sampling rate and the high compression mode are processed.

In the transmitting part of the device, the transmitter is used to carry out the voice picking from the MIC, then analog vibration signal is converted to digital signal by the A/D, digital signal is modulated with FSK mode, the modulated signal is sent out through the rail vibration signal.

The receiver with high sensitivity sensor captured the vibration signal, then amplified and filtered signal to A/D converter, then the software demodulate signal, the original information is recovered and received.

3 Key technology of system

3.1 The emergency communication system frame

The entire communication system works by using peer to peer strategy, each terminal device consists of two parts, transmitter and receiver. The signal in transmission channel is different with wireless or wired communication system. Here, the signal is mechanical elastic wave, communication mode is similar to the way the Morse code. At generally, the trapped Survivors instinct knock the track to contact with the rescue team for help in accident, while wireless and wired communication are not available.

However, the information expressed by the person irregularly hitting action is limited, which can only be used to indicate that a person is trapped, and cannot accurately transmit the trapped position and other key information. This is a very primitive way of emergency communication, we need to set up a whole schedule to transmit comparative complex information. Unlike general communication equipment, the mechanical wave is used as transmission wave, and rail is as transmission medium. The detail frame of communication is as Fig. 8.

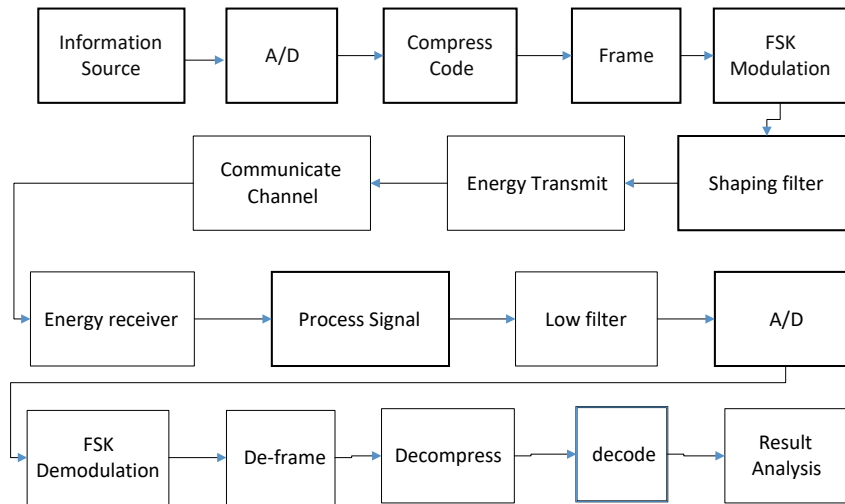

Figure 8: Frame of communicate system based on rail

In system, if input source is voice, then sound is sampled and converted into digital signal; if input source is words, then direct into compress code module. Speech signal is matched firstly, then is compressed to code, in order to reduce the amount of information transmission, the datum are assembled the special Ethernet mac frame, the system use FSK mode to modulate the frame data, modulated datum are sent to shape filter, filtered datum drives the vibrator to rail track to transmit information in the track channel.

The vibration sensor with high sensitivity receives the vibration signal at the receiver, the receiver processes the received signal, such as amplifying, filtering, and so on. The processed signal is converted to digital signal, the system software demodulates FSK signal, defames the Ethernet frame data, decompresses the frame data, decodes the signal to recover the initial signal, displays or speaks the information, to realize voice communication.

The source maybe a segment of voice or several simple words, in the actual environment, the best ways is to provide two kinds of input accepted. We have study the voice signal, the size of voice signal is large relative to the channel capacity.

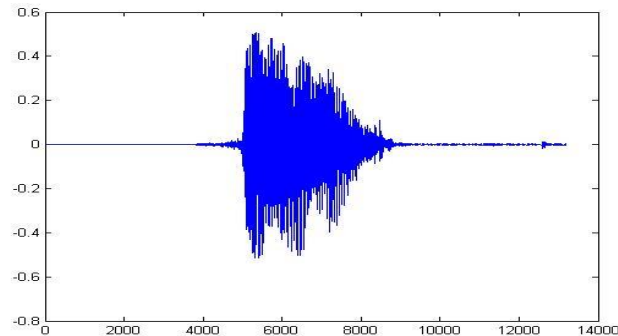

Figure 9: Wave data of speech

The Fig. 9 is the wave of voice that the trapped speak number '3' in Chinese, with 8K sample rate. Even that, the size of file is up to 53k bytes, if the sample rate is higher, the size is bigger.

Waveform interpolation algorithm shows good performance and produces high detected speech at the less to rate of 2 Kbs. However, this coding algorithm is very complexity in computation. It is difficult to be realized in the terminal equipment for emergency communication.

In the study of very low rate coder algorithm, multi frame joint matrix quantization is approved is an efficient method for realizing the high quality and low rate speech code [Lin, Juan and Kun (2004)]. The alignment process is removed at the coding end, and three times spline model is applied at the decoding side. Low frequency component is quantified in the slow gradient waveform justly, and the fast gradient waveform is fitted with orthogonal polynomials, and the complexity of the algorithm is further reduced.

The method of reducing rate of speech in this system is to match the sampled voice data to text data in the terminal device. The transmitting device matches the text information of the speech signal in the local database, and converts the speech information into the text information in the dictionary, thereby reducing the speech information.

We found that the quantity of information in the mine emergency communication is limited through experiments, we can enumerate the key information fully.

Due to the limitation of channel bandwidth, the direct transmission of high quality speech signals has some problems, such as large data volume, long transmission delay time and large error rate. Considering the particularity of the rescue communication system, it is advisable to transmit reliable and useful key information as far as possible. Therefore, the following communication strategies are adopted within the transceiver:

- 1) Key information is preset in every device node. Nodes can automatically send default information, such as node identifier, when the trapped men turn on the machine.
- 2) Text input mode is priority to reduce system information transmission.

- 3) Low sampling rate is applied to input voice signals to reduce the datum of the input signals.
- 4) Intelligent speech recognition is integrated in transmission system, which performs fuzzy matching on the sample speech signals, and the matched signals are transmitted to text information.
- 5) If the voice signal cannot be matched, the speech information is compressed with high loss rate.

Rail is mainly composed of three main parts, track, sleeper, support plate. These three parts have great influence on the transmission parameters of the whole channel. They directly determine the communication capacity of the channel. We have done many experiments, stimulate frequency is from 50 Hz to 3 kHz, that according to the specific of our excitation and receive equipment.

The waveform and frequency spectrum of signal at the data acquisition terminal are as follow after the periodic excitation signal is applied to the track.

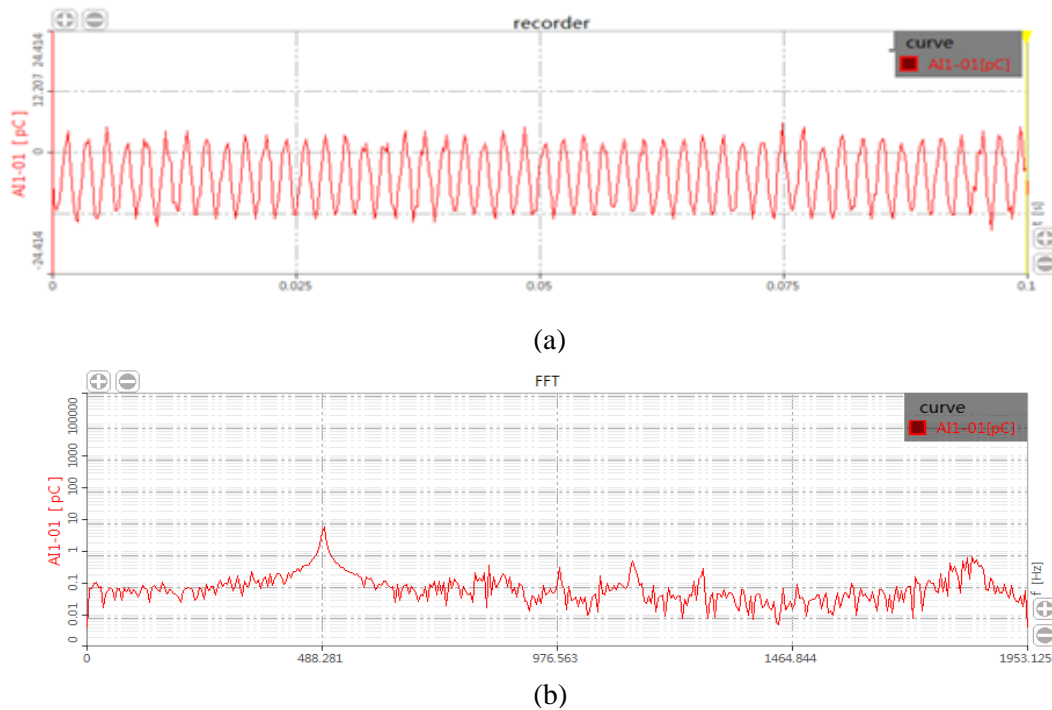

Figure 10: Spectrum of transmitting signal

From analyzing the spectrum of transmitting signal, we can know the periodic vibration signal is obviously bigger 10 dB than background noise. So we can use the vibration sensor to recover the signal from the track.

We also found in the underground rail track, the nearby 1 kHz signal can be detect good by our sensor. If the excite frequency of signal is from 0.1-1 kHz, the system bandwidth of $B=1$ KHz.

We assume that the typical signal-to-noise ratio of mine railway is about 10 dB, namely $S/N=10$, according to Shannon theory, the capacity of channel is as follow:

$$C = B \log_2(1 + S/N) \quad (8)$$

Then we resolve to obtain the expressions of maximum capacity of channel:

$$C = 1000 * \log_2(1 + 10) \quad (9)$$

Approximately equal to 4K, this is a very small capacity.

Therefore, if the SNR of transmission channel cannot be improved, the emergency communication system will not reach higher transmission rate, that means, the capacity is lower.

Since the emergency system is in the complex environment, the signal is interfered by noise severely, and noise mainly includes white noise and burst impact noise. Therefore, the communication system should have strong anti-interference ability. The modulation mode of this system choice 2FSK for the strong anti-jamming ability. That is,

$$S(t) = S_1(t) \cos \omega_1 t + S_2(t) \cos \omega_2 t \quad (10)$$

Here $S_1(t)$ means signal '0', and $S_2(t)$ means signal '1'

$$S_1(t) = \sum_n a_n g(t - nT_s) \quad (11)$$

$$S_2(t) = \sum_n b_n g(t - nT_s) \quad (12)$$

Carrier signal is modulated with FSK in transmitting terminal, and sinusoidal signal produced by modulator is sent to the exciter, which generates the vibration signal to hit rail, and sends vibration signal to rail.

Based on the previous analysis, we simulated the noisy communication channel, and constructed the entire communication system in MATLAB. In the white noise channel environment, we can realize communication based on FSK modulation.

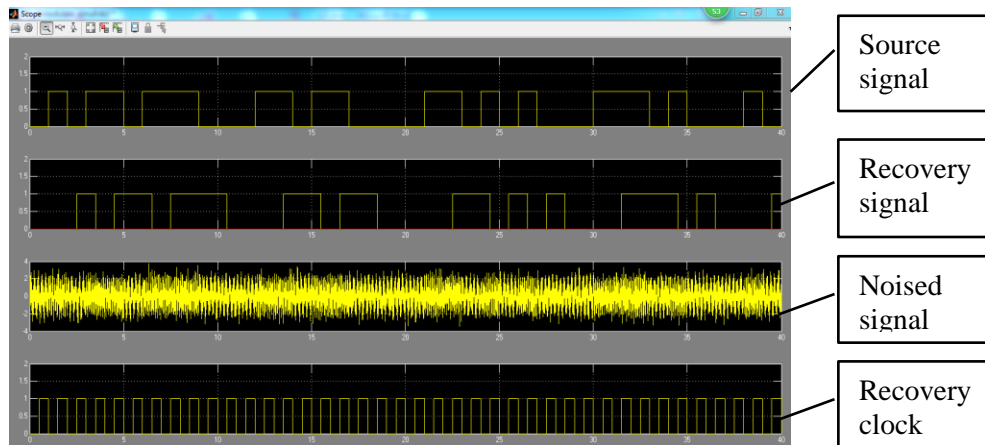

Figure 11: Simulation results

3.2 Communicate protocol

From the above analysis, the capacity of system is so small, a fit communication protocol is vital, the layer protocol helps to ensure the efficiency and reliability of information

transmission [Jin, Chong and Taeshik (2008)]. Stratification helps separate the tasks and responsibilities of different levels, and provides services between different layers through the interface. In addition, the layered design cannot be too modular, making the processing heavy.

Because the amount of transmission data in the emergency communication system is small, and communication framework is peer to peer, there is no need for complicate networking. The communication protocol is equivalent to direct to hardware, so the data frame should have a certain capacity for fault tolerance. It is necessary to add check sum in the data frame. In view of the characteristics of low speed emergency communication of rail track, the layer of the system is as follows:

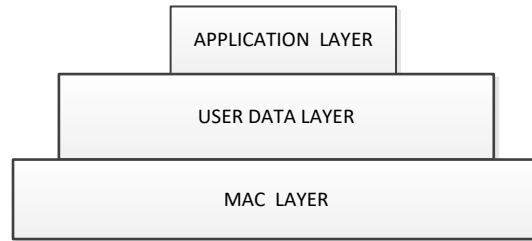

Figure 12: Layer of communication system of rail track

While guaranteeing the reliability of transmission, the communication protocol takes into account the efficiency of transmission at the same time. That is, we need to increase the proportion of effective net payload in the data frame as far as possible, and we propose it on the basis of mature communication protocol, make it conform to the characteristics of this system. As mentioned earlier, in this system, peer-to-peer communication is general between receiver and transmitter, which make it possible to simplify the existing communication protocol to the emergency system based on vibration.

In the railway emergency communication, we use the simplified MAC protocol frame as basic communicate frame.

Unlike ordinary network data frames, there are two kinds of data frames used to transmit information in this system. One is used to transmit big data, and the other is used to transfer simple text or command information, such as the amplitude of the signal, the preset node information, and so on.

Considering the amount of voice information data is large and channel bandwidth is small, in order to reduce overhead proportion in the frame, the system defines a big data frame of 512 bytes per frame based in the MAC frame.



Figure 13: Define of big data mac frame

For voice information, the error frame does not be transmitted again, even if there is error occurred, since the chance error is accepted under the circumstances that do not influence the key information to transmit.

On the contrary, the information of control frame is small and critical to user, so it should be avoid the error during the transmission process.

Reliability is the primary consideration of key information frames. Therefore, enhanced measures are implemented on the basis of conventional communication protocols.

The system defines 64 bytes small frame for redundant transmission.

DMAC	SMAC	TYPE	SN	PAYLOAD	FCS1	SN	PAYLOAD	FCS2	FCS
------	------	------	----	---------	------	----	---------	------	-----

Figure 14: Define of control mac frame

3.3 Composite location algorithm

The algorithm of locating survivors is always a hot spot in the research of emergency communication. Several major location techniques have been proposed in many literatures. Such as, time of arrival (TOA), time difference of arrival (TDOA), different solutions based on angle of arrival (AOA), and received signal strength Indicator (RSSI) [Hu, Zhang, Wu et al. (2016); Ito, Anzai and Wang (2016)].

In these methods, parameters of channel, such as time-vary characteristic, multipath propagation severely affect the accuracy and precision of localization system.

According the specific attenuation model, when the vibration wave transmits in the rail steel, the signal will produce the corresponding attenuation. Through the analysis of the signal attenuation model, we can obtain the corresponding location of vibration source that can provide clues for carrying out rescue activities.

Concerning the complicate circumstance in the tunnel, we proposed a location algorithm, which contains a hybrid method for localization based on RSSI measurements, node encode detect, and method based on the bidirectional delay derived of FRC2544 standard for network, these three factors have different weight in the algorithm.

When the vibration signal is transmitted in the rail, accord to the specific attenuation model, the frequency and waveform of the useful signal will not change with the attenuation of the signal, the corresponding attenuation will be calculated. By the analysis of the attenuation, the general position of the corresponding signal source can be obtained, thus providing clues to the rescue team.

Firstly, only the longitudinal wave transmits in rail. If the amplitude of vibration signal of transmitter is A_r , and the amplitude of receiver is A_d , the attenuation factor of the rail can also be measured, and the attenuation formula of the longitudinal wave is:

$$T = 20 \log \left(\frac{A_d}{A_r} \right)$$

By studying the attenuation characteristics of the medium and the experimental data, the propagation distance of the vibration in rail can be calculated: $L1 = T * C_1$. The longitudinal propagation velocity of vibration wave in rail, C_1 , can be deduced from Eq. (2).

When we design the equipment, the identity information of device can be contained in the transmitting device. When the rescuer receives the vibration information, the identity information of the equipment can be identified, thus the positioning of the personnel can

also play a reference role.

Second method is to preset the location information at each node, and to establish a deep unified database before the accident occurs. So, even if a mine accident occurs, the pre-tested data L2 can be one of the survivor location credentials before the track has not been greatly deformed.

The third positioning method based on bidirectional delay in the system is derived from the RFC2544 test method of LAN. The device of trapped personnel works in the automatic loop state, the rescue side sends the test frame with timestamp T1, the loop back side handles the test frame, switch source mac to destination mac. The rescue side receives the test frame after processing, gets the timestamp T2, and carries on the post processing, and obtains the transmission delay time of the test frame actually in the channel.

$$DT = (T2 - T1 - Tre)/2 \quad (13)$$

Here, T2 is the final time tag, T1 is the initial time tag, and Tre is the inherent time consumed by the loopback side. The propagation distance of the vibration in rail can be calculated: $L3=DT * c_1$. This test method is not related to signal amplitude and frequency. Combined with the above three positioning methods, the final location of trapped personnel can be obtained as follows:

$$L=\lambda_1L_1+\lambda_2L_2+\lambda_3L_3 \quad (14)$$

4 Discussion

There are a lot of technical and commercial barriers hampering the realization of the emergency communication in mine tunnel. Technical barriers consist of complicate and diverse field environment, the random parameters of channel medium. Just a single communication mode is not fitting to all circumstance.

In this paper, we assume that the rail track is continuous, and assume that only one trapped survivor communicates with the rescue team at one time. In this case, we do not need to consider the mutual interference between different nodes, and the model of channel is simplified to time invariant system.

But the actual situation may be very complex, there may be many rail joints, there may be bifurcation situation, all these conditions will result that the characteristics of the transmission channel is inconsistent, the signal attenuation coefficient is changed. Furthermore, the actual rail is laid on the roadbed, the attenuation coefficient will also be affected by other factors. Therefore, the field test should be carried out to correct the system model.

4.1 Channel diagram without passing branch

In actual disasters, attenuation of vibration signals through buried objects is related to impedance and medium density. Attenuation factor can be varied according to the density model of different buried objects. The receiver calculates and gets the deduction about location of the trapped person by distance by analyzing attenuation, frequency and other characteristic information of the received signal. The location diagram is shown in Fig. 15.

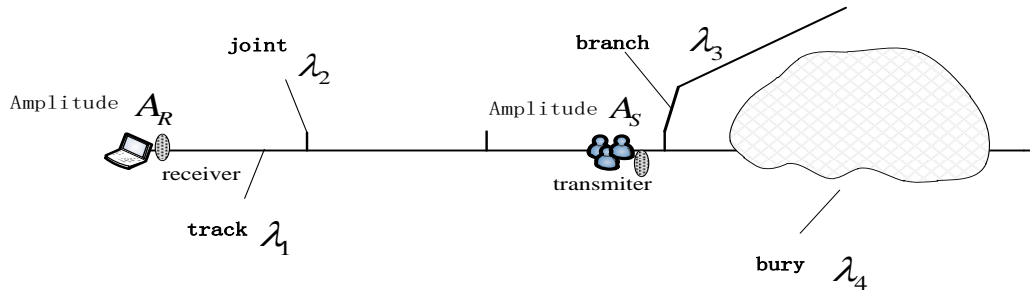

Figure 15: Channel diagram without passing branch

The vibration signals will be attenuated when the signals pass rail, joint, branch and buried objects, and so on. Attenuation coefficient are λ_1 , λ_2 , λ_3 , λ_4 respectively. If the amplitude of the sending signal is A_d , the amplitude of the receiving side is A_r , the attenuation factor of the rail will be $\lambda_1 = 20 \log\left(\frac{A_d}{A_r}\right)$.

Similarly, λ_2 , λ_3 , λ_4 can be measured with the same method. The amplitude of vibration signal at the sending side is fixed to A_s , if the signals do not pass through branches and buried objects. The amplitude of vibration signal at rescue team side is A_r , the attenuation factor of signal is as Eq. (15).

$$\Delta = 20 \log\left(\frac{A_s}{A_r}\right) = n \cdot (\lambda_1 + \lambda_2) \quad (15)$$

The number of track which signals pass is n . As follows:

$$n = \frac{\Delta}{\lambda_1 + \lambda_2} \quad (16)$$

In actual circumstance, the length of track is known, and once the number of rails can be calculated, we can get the roughly position of trapped personnel. Supposing the length of a track is l , then the total distance is probably: $x = n * l$, that is:

$$x = \frac{\Delta}{\lambda_1 + \lambda_2} * l \quad (17)$$

4.2 Channel diagram with passing branch

When the vibration signals pass through a branch, it is shown in Fig. 16.

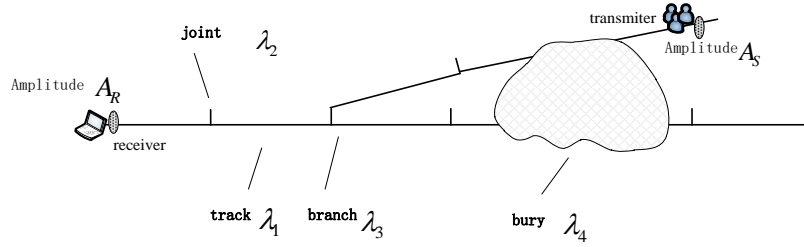

Figure 16: Channel diagram with passing branch

When the vibration signals pass through a branch road, due to the influence of the branch and the buried objects, the total attenuation is as follows:

$$\Delta' = 20 \log \left(\frac{A_S - N\lambda_3 - \lambda_4}{A_R} \right) \tag{18}$$

Then the probably distance is as follows:

$$x' = \frac{\Delta'}{\lambda_1 + \lambda_2} * l \tag{19}$$

4.3 The influence of multipath, gap to elastic wave

Multipath, gap on channel of vibration signal will have the corresponding attenuation respectively. Since the length of gap, and the circumstance of multipath are vary, the transmission parameters of channel are not constant. The distance based attenuation justly is not accuracy. We need some other issues to complementary the error. These conditions maybe as follow:



Figure 17: Rail with multipath and gap

After the mine accident, the track may fracture under the impact of rock or explosion. When the vibration signal is transmitted from rail to air, the attenuation of the signal mainly comes from reflection and refraction of the signal. The simplest fracture model is that the fracture surface is perpendicular to the rail, the vibration signal is in normal condition. Relationship between incident angle A, refraction angle B and the wave velocity satisfy the following law of refraction at the junction of different media:

$$\frac{\sin \alpha}{v_1} = \frac{\sin \beta}{v_2} \quad (20)$$

The magnitude of reflected and refraction wave is related to the characteristic impedance of the medium $Z = \rho v = \sqrt{E\rho}$, and E is strength modulus of waveform. The reflectivity and transmittance are deduced as follow at positive incidence:

$$R = \frac{Z_1 - Z_2}{Z_1 + Z_2} \quad (21)$$

$$T = 1 - R = \frac{2Z_2}{Z_1 + Z_2} \quad (22)$$

The unit attenuation factor of incident wave is $20 \text{ Log}T$. The signal attenuates $\lambda = 2\pi r l \sigma$ after passing a gap or multipath. Fracture surface will be more complicated at the most situation. According to different conditions, we can construct the specific model of vibration signal attenuation for multipath and gap.

4.4 The condition of channel deform

Because the rail is made of high strength hardness materials, the most common deformation of rail under the impact of external force is small angle bending after the accident as shown in Fig. 18.

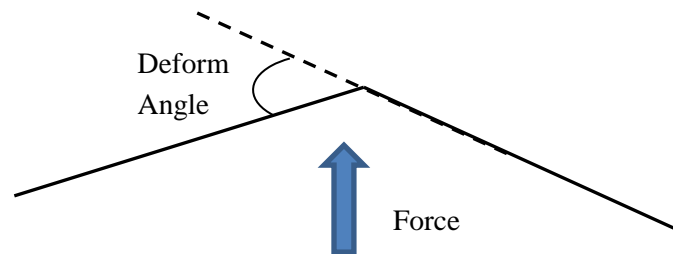

Figure 18: Deform figure of rail track by external force

From the definition and description of the total reflection of the vibration signal, it is known that if the characteristic impedance of the two medium is quite different, the incident angle or the refraction angle is not close to 90 degrees, the energy reflection is basically complete. In this case, the vibration signal is total reflection, and attenuation can be ignored.

Rail is subjected to bending at a large angle in very few cases, under this condition, the attenuation of signal can be obtained by the reflection law of vibration signal.

5 Conclusion and further research

This thesis has made a research to the mechanism and principle of emergency communication based on rail, analyzed the attenuation characteristics of vibration signals in tunnel rails. Through a large number of indoor and environmental experiments on the spot, the major findings of the present study are summarized as follows:

- 1) The rail in the mine is not easy to break in the disaster, the emergency communication system based on rail can realize communication between the trapped personnel and the rescue team with vibration carrier wave. But the speed is less, information capacity is small for voice signal with error.
- 2) The composite algorithm of location can estimate the position of the trapped survivors in simple environment. The error increases with noise strength, number of joints.
- 3) Other non-folding pipelines in the mine can also learn from the rail communication mechanism and positioning method for emergency communication [Wang and Gao (2015)].

Further research on the emergency communication technology based on railway can be carried out in many aspects. The method of mixed communication is used to increase the reliability and the resistance of the whole emergency communication system, the wireless relay device can be added at different working nodes to realize the signal regeneration. At the same time, it can also make use of wireless communication to realize the redundancy of the channel.

Acknowledgements: The authors would like to thank National Natural Science Foundation of China for the grant of the project (41574137). Furthermore, they would like to specially thank Prof. Guo Yong for his contributions and his support in this paper.

References

- Bernas, M.; Placzek, B.** (2015): Fully connected neural networks ensemble with signal strength clustering for indoor localization in wireless sensor networks. *International Journal of Distributed Sensor Networks*, vol. 2015, pp. 1-10.
- Dashti, S.; Bray, J. D.; Reilly, J.; Glaser, S.; Bayen, A. et al.** (2014): Evaluating the reliability of phones as seismic monitoring instruments. *Earthquake Spectra*, vol. 30, no. 2, pp. 721-742.
- Han, R.; Zhao, X.; Yu, Y.; Guan, Q.; Peng, D. et al.** (2016): Emergency communication and quick seismic damage investigation based on smartphone. *Advances in Materials Science and Engineering*, vol. 2016, pp. 1-15.
- Hu, Q.; Zhang, S.; Wu, L.; Ding, E.** (2016): Localization techniques of mobile objects in coal mines: challenges, solutions and trends. *Journal of China Coal Society*, vol. 41, no. 5, pp. 1059-1068.
- Ito, T.; Anzai, D.; Wang, J.** (2016): Hybrid TOA/RSSI-based wireless capsule endoscope localization with relative permittivity estimation. *IEICE Transactions on Communications*, vol. E99-B, no. 11, pp. 2442-2449.
- Jin, H. K.; Chong S. H.; Taeshik, S.** (2008): A lightweight NEMO protocol to support

6LoWPAN. *ETRI Journal*, vol. 30, no. 5, pp. 685-695.

Karlinski, J.; Ptak, M.; Dzialak, P.; Rusinski, E. (2016): The approach to mining safety improvement: Accident analysis of an underground machine operator. *Archives of Civil and Mechanical Engineering*, vol. 16, no. 3, pp. 503-512.

Kilinc, F. S.; Monaghan, W. D.; Powell, J. B. (2014): A review of mine rescue ensembles for underground coal mining in the united states. *Journal of Engineered Fibers and Fabrics*, vol. 9, no. 1, pp. 174-185.

Lin, L. J.; Juan, C. H.; Kun, T. (2004): Efficient LSP quantization algorithm for very low bit rate speech coding. *Journal of Tsinghua University*, vol. 44, no. 10, pp. 1422-1425.

Reina, D. G.; Ruiz, P.; Ciobanu, R.; Toral, S. L.; Dorronsoro, B. et al. (2016): A survey on the application of evolutionary algorithms for mobile multihop ad hoc network optimization problems. *International Journal of Distributed Sensor Networks*, vol. 2016, pp. 1-13.

Radko, V. A.; Vasiliev, Y. R. (2011): Linking mantle plumes, large igneous provinces and environmental catastrophes. *Nature*, vol. 477, no. 7364, pp. 312-316.

Sobolev, S. V.; Sobolev, A. V.; Kuzmin, D. V.; Krivolutskaya, N. A.; Petrunin, A. G. et al. (2011): Linking mantle plumes, large igneous provinces and environmental catastrophes. *Nature*, vol. 477, no. 7364, pp. 312-316.

Wang, W.; Cheng, Y. P.; Wang, H. F.; Liu, H. Y.; Wang, L. et al. (2015): Fracture failure analysis of hard-thick sandstone roof and its controlling effect on gas emission in underground ultra-thick coal extraction. *Engineering Failure Analysis*, vol. 54, pp. 150-162.

Wang, W.; Cheng, Y. P.; Wang, H. F.; Li, W.; Wang, L. (2015): Coupled disaster-causing mechanisms of strata pressure behavior and abnormal gas emissions in underground coal extraction. *Environmental Earth Sciences*, vol. 74, no. 9, pp. 6717-6735.

Wang, F. T.; Tu, S. H.; Yuan, Y.; Feng, Y. F.; Chen, F. et al. (2013): Deep-hole pre-split blasting mechanism and its application for controlled roof caving in shallow depth seams. *International Journal of Rock Mechanics and Mining Sciences*, vol. 64, pp. 112-121.

Wang, X.; Gao, Y. (2015): Signal design of pipe emergency acoustic communication. *Modern Electronics Technique*, vol. 38, no. 1, pp. 79-82.