

The Out-of-Plane Strain Measurement of Composite Sandwich Plate with Fully-Potted Insert Using Digital Phase-Shifting Shearography

Song-Jeng Huang¹ and Yan-Fu Liu²

Summary

A digital shearographic (DS) technique is a tool well-suited for precision strain measurement and is a nondestructive testing technology. But the fringe patterns of shearography are not so clear. A phase-shifting technique is incorporated into DS and demonstrated to yield fringe patterns with good quality.

The major purpose of this study is to produce a measuring system of digital phase-shifting shearography (DPSS) to measure out-of-plane strain of sandwich plate with fully-potted insert. The system mainly includes piezoelectric transducer, servo controller, Michelson shearing mechanism, image processing system and loading system. The Macy algorithm is used for program simulation, and applying noise examined the influence after phase unwrapping. The four-step phase shifting method is used to obtain phase map and then the phase expansion is proceeded by Macy algorithm to obtain the out-of-plane strain $\left(\frac{\partial w}{\partial x}\right)$ of honeycomb sandwich plate with insert/potting material. Finally, comparing out-of-plane strain of DPSS with DS shows about 2% to 7% difference.

Introduction

Sandwich plates have widely been used in the aerospace, shipbuilding, construction and other industries. The introduction of loads into such structural elements is often accomplished by using fasteners or inserts, which can be of the 'partially potted,' 'through-the-thickness' or 'fully potted' type [1].

Thomsen et al. [1] introduced a high-order sandwich plate theory to derive governing equations for both sandwiches with 'through-the-thickness' inserts and that with 'fully potted' inserts. Noirot et al. [2] studied the experimental and 3D finite element model analysis to describe the breaking points of five kinds of inserts while being pulled out.

The technique of ESPI was invented in the early 1970s (Butters and Leendertz [3]; Macovski et al. [4]). ESPI has been used to measure out-of-plane displacements of the test surface, in-plane displacement, displacement gradients and also monitoring of vibrations. A digital shearographic (DS) technique is a tool well-established for precision strain measurement and is also a nondestructive testing

¹Department of Mechanical Engineering, National Chung Cheng University, Ming-Hsiung, Chia-Yi, 621, TAIWAN

²Department of Mechanical Engineering, National Chung Cheng University, Ming-Hsiung, Chia-Yi, 621, TAIWAN

technology [5]. Digital phase-shifting shearography (DPSS) techniques are a powerful tool to calculate strain quantitatively [6].

3-D shape measurement of composite structures by DS [7] and out-of-plane surface displacement of sandwich plate by using ESPI [8] were introduced. To the authors' knowledge, there exist surprisingly few reports on DPSS measurement of sandwich panels with insert. The objective of this paper is to measure a full-field out-of-plane strain $\left(\frac{\partial w}{\partial x}\right)$ of sandwich plates with single "fully potted" inserts loaded by tensile stresses through DPSS. For validation purpose, the experiment result is then compared with DS analysis results of Huang et al. [9].

Digital shearography

In digital shearography, the phase change is the phase difference between two shearing points on the test object surface, as shown in Figure 1. The object is illuminated by an expanded He-Ne laser beam at an incidence angle θ . Points $S(x_S, y_S, z_S)$ and $O(x_O, y_O, z_O)$ represent the position of the light source and the position of observation, respectively. Consider a point $P_1(x, y, z)$ on the surface of the object and a neighboring point $P_2(x + \delta x, y, z)$, which is a small distance δx in a x direction from $P_1(x, y, z)$. Assuming that the amount of shear is δx on the object surface, the rays from the points P_1 and P_2 pass through the shearing device and interfere with each other on the CCD target in the image plane. Through some calculations of points P_1 's and P_2 's light paths before and after deformations, the following equations could be obtained:

$$\phi_1 = \frac{2\pi}{\lambda} \delta L_1 \quad (1)$$

$$\phi_2 = \frac{2\pi}{\lambda} \delta L_2 \quad (2)$$

where ϕ_1 and ϕ_2 are the relative phase changes related to δL_1 and δL_2 , respectively; δL_1 and δL_2 are the light path changes between the light source S to the camera at O via point P_1 and P_2 , and that between the light source S to the camera at O via point P_1 and P_2 , respectively.

$$\Delta_x = \frac{2\pi}{\lambda} \left(C_1 \frac{\delta u}{\delta x} + C_2 \frac{\delta v}{\delta x} + C_3 \frac{\delta w}{\delta x} \right) \delta x \quad (3)$$

where $\Delta_x (= \phi_2 - \phi_1)$ is the relative phase changes before and after deformation.

Hence, if we put source S and observation O on the same $x - z$ plane, also set the incidence angle of source and reflective angle to observation both equal to zero, equation (3) could be simplified as:

$$\frac{\partial w}{\partial x} = -\frac{\lambda}{4\pi \delta x} \Delta_x = -\frac{n\lambda}{2\delta x} \quad (4)$$

where n is the fringe order of dark fringe. If we use phase-shifting technique, the whole-field strain $\left(\frac{\partial w}{\partial x}\right)$ may be obtained by substitute Δ_x into equation (4).

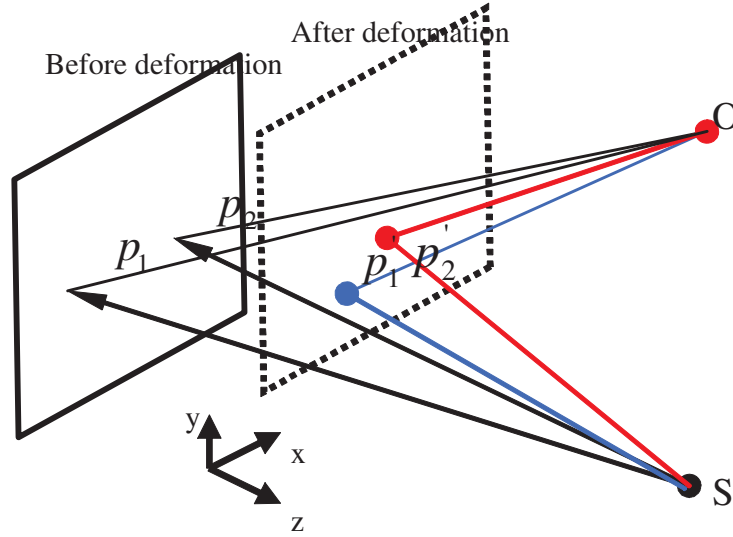

Figure 1: Scheme for optical paths in digital shearography; Coordinates of the points.

Phase-Shifting Technique

A phase-shifting technique is used to determine phase distribution in fringe patterns. The phase measurement is based on superimposing a uniform phase $\delta\phi$ on the original fringe pattern. Here, the additional uniform phase is introduced by tilting the object, and the four-frame method is used [10]. When the additional phase $\delta\phi$ is $0, \pi/2, \pi,$ and $3\pi/2$, the light intensities corresponding to these additional phases are $I_1(x, y), I_2(x, y), I_3(x, y),$ and $I_4(x, y)$, respectively.

$$\begin{aligned}
 I_1 &= I_r + I_o + 2(I_r I_o)^{\frac{1}{2}} \cos\left(\phi - \frac{\pi}{2}\right) \\
 I_2 &= I_r + I_o + 2(I_r I_o)^{\frac{1}{2}} \cos(\phi) \\
 I_3 &= I_r + I_o + 2(I_r I_o)^{\frac{1}{2}} \cos(\phi + \Delta) \\
 I_4 &= I_r + I_o + 2(I_r I_o)^{\frac{1}{2}} \cos\left(\phi + \Delta + \frac{\pi}{2}\right)
 \end{aligned}
 \tag{5}$$

Mathematically, $\Delta x(x, y)$ can be determined by

$$\Delta_x(x, y) = 2 \tan^{-1} \left[\frac{I_3(x, y) - I_2(x, y)}{I_4(x, y) - I_1(x, y)} \right]
 \tag{6}$$

Equation (6) would generate the phase values wrapped in module 2π and the differential phase angle between two consecutive fringes is in multiples of 2π (i.e. $2\pi n$). Hence, the phase values must be unwrapped to obtain the fringe order n using the subtraction or linear correlation algorithms [11]. This may then be used in equation (4) to determine the out-of-plane strain of object.

Construction of the DPSS system

The schematic diagram of the experimental setup is shown in Figure 2. The system consists of a He-Ne laser, 2 mirrors, a beam splitter (7cm diameter) used as shearing device, a mirror attached to a piezoelectric transducer (PZT), PZT servo controller, CCD camera, and personal computer (PC). The shearing device brings two nonparallel beams scattered from two different points on the object surface to become nearly co-linear and interfere with each other. The two waves overlap to form interfereograms at the CCD plane.

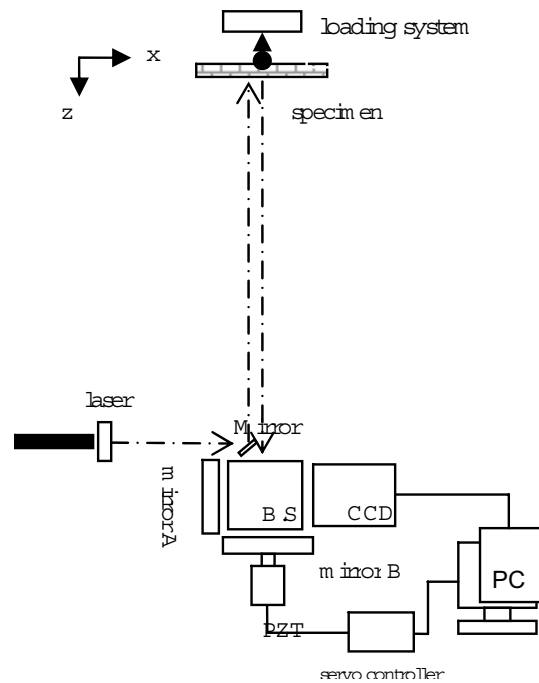

Figure 2: DPSS experimental setup for out-of-plane strain measurements.

The DPSS experimental configuration for single-inserted sandwich plate is shown in Figure 3. A test fixture was made to hold the specimen and expose a free circular area 70 mm in diameter. Therefore the sandwich plate rests on the circular hole to reproduce simply supported boundary conditions at the circumference ($r = 70$ mm). Loads are applied at the inserts of single-inserted sandwich specimen,

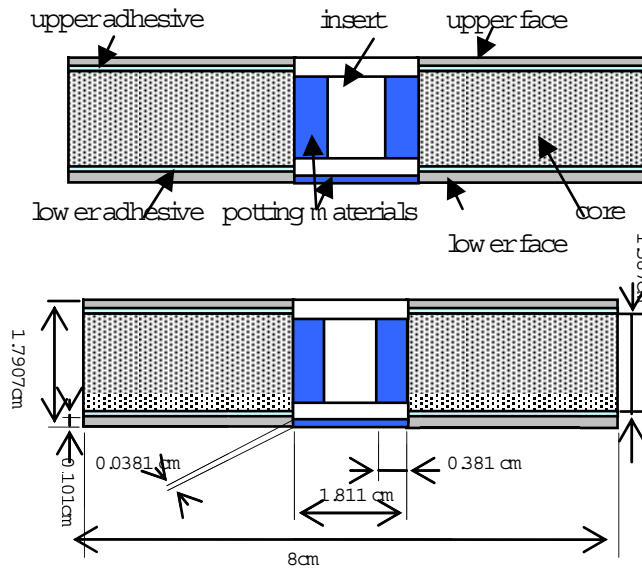

Figure 3: Geometric configuration of sandwich specimen for experiments.

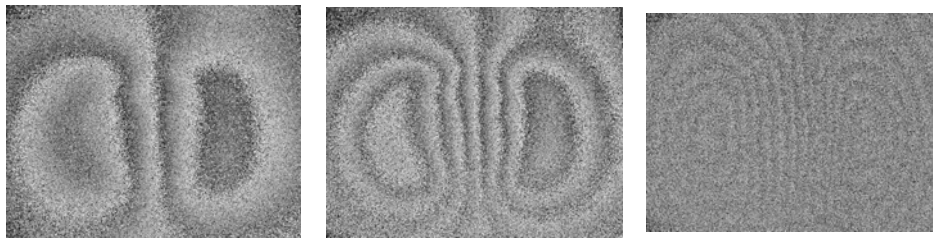

Figure 4: Phase map under 3 kg loading Figure 5: Phase map under 6 kg loading Figure 6: Phase map under 9 kg loading

which range from 0 to 9 kg with suitable loading velocity.

Results

The results of DPSS of sandwich specimens loaded up to 3, 6, and 9 kg are shown in figures 4–6. The phase value of each interfereogram then unwrapped and reconstructed by software MATLAB to obtain the strain field of sandwich plates, as shown in Table 1. Table 1 shows the comparison of strains between DS and DPSS, in which a convincing agreement is revealed.

References

1. Thomsen, O. T. (1988): “Sandwich Plates with ‘Through-The-Thickness’ and ‘Fully Potted’ Inserts: Evaluation of Differences in Structural Perfor-

Table 1: Strain $\left(\frac{\partial w}{\partial x}\right)$ distributions obtain by DPSS and DS

	x, (mm)	$\frac{\partial w}{\partial x}$ by DS	$\frac{\partial w}{\partial x}$ by DPSS	Difference between DS and DPSS, (%)
Under loading 9kg	-20	8.79×10^{-4}	8.34×10^{-4}	5.1
	-15	0.11×10^{-4}	0.106×10^{-4}	3.6
	-10	9.56×10^{-4}	9.13×10^{-4}	4.5
	-5	5.6×10^{-4}	5.5×10^{-4}	1.8
	5	-5.5×10^{-4}	-5.35×10^{-4}	2.7
	10	-9.58×10^{-4}	-9.29×10^{-4}	3.1
	15	-0.13×10^{-4}	-0.13×10^{-4}	3.4
	20	-0.12×10^{-3}	-0.115×10^{-4}	3.8

mance”, *Composite Structures*, Vol. 40, pp.159–174.

- Noirot, F, Ferrero, JF, Barrau, JJ, Castanie, B, Sudre, M. (2000) : “Analyse d’inserts Pour les Structures Sandwich Composites”, *J Mech Ind*, Vol. 1, pp.241–249.
- Butters, JN, Leendertz, JA. (1971): “Holographic and Video Techniques Applied to Engineering Measurements”, *J Meas Control*; Vol. 4, pp. 349.
- Macovski, A, Ramsy, D, Schaefer, LF. (1971): “Time-Laps-Interferometry and Contouring Using Television Systems”, *J Appl Optics*, Vol. 10, pp.2722-2727.
- Hung, Y. Y. and Liang, C. Y. (1979): “Image-Shearing Camera for Direct Measurement of Surface Strains,” *Appl. Opt.*, Vol. 18, No. 7, pp. 1046–1051.
- Hung, Y. Y. and Wang, J. Q. (1996): “Dual-beam Phase Shift Shearography for Measurement of In-plane Strains”, *Optics and Lasers in Engineering*, pp. 403-413.
- Hung, Y. Y. (1999): “Application of Digital Shearography for Testing of Composite Structures”, *Composites: Part B*, Vol. 30, pp. 765-773.
- Huang, S. J., Lin, H. L. (2004): “Electronic Speckle Pattern Interferometry Applied to the Displacement Measurement of Sandwich Plates with Single ‘Fully- Potted’ Insert”, *Journal of Mechanics*, Vol. 20, pp. 273-276.
- Huang, Song-Jeng, Lin, Yu-Tan, Hsiao, Ming-Zi, Dec. 10, (2005): “Digital Speckle Pattern Shearography Applied to the Out-of-Plane Strain Measurement in Sandwich Plates with Insert and Potting Materials”, Proceeding of 2005 AASRC/CCAS Joint Conference, Taichung, Taiwan, paper no. S02.

10. Hong, C. K., Ryu, H. S., and Lim, H. C. (1995): “Least-Squares Fitting of the Phase Map Obtained in Phase-shifting Electric Speckle Pattern Interferometry”, *Optics Letter*, Vol. 20, No. 8, pp. 931-933.
11. Tay, C. J., Quan, C. and Shang, H. M. (1998): “Shape Identification Using Phase Shifting Interferometry and Liquid-Crystal Phase Modulator”, *Optics & Laser Technology*, Vol. 30, pp. 545-550.

