

Numerical Solution of Fuzzy Equations with Z-numbers using Neural Networks

Raheleh Jafari^a, Wen Yu^a and Xiaoou Li^b

^aDepartamento de Control Automático, CINVESTAV-IPN (National Polytechnic Institute), Mexico City, Mexico; ^bDepartamento de Computación, CINVESTAV-IPN (National Polytechnic Institute), Mexico City, Mexico

ABSTRACT

In this paper, the uncertainty property is represented by the Z-number as the coefficients of the fuzzy equation. This modification for the fuzzy equation is suitable for nonlinear system modeling with uncertain parameters. We also extend the fuzzy equation into dual type, which is natural for linear-in-parameter nonlinear systems. The solutions of these fuzzy equations are the controllers when the desired references are regarded as the outputs. The existence conditions of the solutions (controllability) are proposed. Two types of neural networks are implemented to approximate solutions of the fuzzy equations with Z-number coefficients.

KEYWORDS

Fuzzy equation; Z-number; Fuzzy control

1. Introduction

Uncertainties are inevitable in real systems. Control of an uncertain system is classified in two methodologies; direct and indirect techniques (Feng, 2006). The methodology involves the direct control, which incorporates the uncertain system as a controlling mechanism, whereas the indirect uncertain model is used to approximate the nonlinear system as a first step, then proceeds controller design based on uncertain model. The indirect fuzzy controller works on the principle of generalized topological structure as well as universal approximation capacity associated to fuzzy model. It has been utilized primarily, considering the case of uncertain nonlinear system control. This paper utilizes the indirect control method.

Since the uncertainty in parameters can be transformed into a fuzzy set theory (Zadeh, 2005), fuzzy set and fuzzy system theory are good tools to deal with uncertain systems. Fuzzy models are applied for a large class of uncertain nonlinear systems. Fuzzy method is a highly favorable tool for the uncertain nonlinear system modeling. The fuzzy models approximate uncertain nonlinear systems with several linear piecewise systems (Takagi-Sugeno method) (Takagi & Sugeno, 1985). Mamdani models use fuzzy rules to achieve a good level of approximation of uncertainties (Mamdani, 1976). In recent days, many methods involving uncertainties have used fuzzy numbers (Buckley & Qu, 1990) (Jafari & Yu, 2015) (Jafarian & Jafari, 2012) (Jafarian, Jafari, et al. 2016), where the uncertainties of the system are represented by fuzzy coefficients.

The application of the fuzzy equations is an in direct connection with the nonlinear control. Given a fuzzy equation, the control incorporated in the equation is in fact a solution of the equation. There are a number of techniques to study the solutions of fuzzy equations. Friedman, Ming, and Kandel (1998) used the fuzzy number on parametric shapes and replaced the original fuzzy equations with crisp linear systems. A survey on the extension principle is proposed by Buckley and Qu (1990) and it suggests that the coefficients can be either real or complex fuzzy numbers. Nevertheless, there will be no guarantee that

the solution exists. Abbasbandy (2006) proposed the homeotypic analysis technique. Abbasbandy and Ezzati (2006) used the Newton methodology. In Allahviranloo, Otadi, and Mosleh (2007) the solution associated to the fuzzy equations is studied by the fixed point technique. One of the most popular methods is the α -level (Goetschel & Voxman, 1986). By applying the technique of overlay of sets, fuzzy numbers can be resolved (Mazandarani & Kamyad, 2013). The fuzzy fractional differential and integral equations have been investigated extensively in Agarwal, Lakshmikantham, and Nieto (2010), Arshad and Lupulescu (2011), Salahshour, Allahviranloo, and Abbasbandy (2012), Wang and Liu (2011). In Khastan, Nieto, and Rodríguez-López (2013), the first-order fuzzy differential equation with periodic boundary conditions is analyzed. Then, higher order linear fuzzy differential equations is studied. In Allahviranloo, Kiani, and Barkhor-dari (2009), the analytical solution of the second-order fuzzy differential equation is obtained. The analytical solutions of third-order linear fuzzy differential equations are found in Hawrra and Amal (2013), while Buckley and Feuring (2001) proposed analytical approach to resolve n th-order linear fuzzy differential equations. Nevertheless, the analytical solutions of fuzzy equations are difficult to obtain and the aforementioned techniques involve greater complexity.

The numerical solution associated to the fuzzy equation and the fuzzy differential equations (Lupulescu, 2009) can be extracted by iterative technique (Kajani, Asady, & Vencheh, 2005), interpolation technique (Waziri & Majid, 2012) and the Runge-Kutta technique (Pederson & Sambandham, 2008). However, the implementations of these techniques are difficult. Both neural networks as well as fuzzy logic are considered to be the universal estimators, which can estimate any nonlinear function to any notified precision (Cybenko, 1989). Recent results show that the fusion of the neural networks and the fuzzy logic gives remarkable success in nonlinear system modeling (Yu & Li, 2004). The neural networks may also be used to solve fuzzy equations. Buckley and Eslami (1997) used a neural network with three neurons to estimate

the second degree fuzzy equation. Jafarian, Jafari, et al. (2015) and Jafarian and Measoomynia (2011) extended the result of Buckley and Eslami (1997) to fuzzy polynomial equations. In Jafarian and Jafari (2012), the solution of dual fuzzy equation is obtained by neural networks. Mosleh (2013) gave a matrix form of the neuronal learning. By extending classical fuzzy set theory, Hüllermeier (1997) obtained a numerical solution for a fuzzy differential equation. The predictor-corrector approach is applied in Allahviranloo, Ahmady, and Ahmady (2007). The Euler numerical technique is used in (Tapaswini & Chakraverty, 2014) to solve fuzzy differential equations. Whatsoever, these techniques are not general, they cannot give the fuzzy coefficients directly with neural networks Tahavvor and Yaghoubi (2012).

The decisions are carried out based on knowledge. In order to make the decision fruitful, the knowledge acquired must be credible. Z-numbers connect to the reliability of knowledge (Zadeh, 2006). Many fields related to the analysis of the decisions use the ideas of Z-numbers. Z-numbers are much less complex to calculate when compared to nonlinear system modeling methods. The Z-number is an abundantly adequate number than the fuzzy number. Although Z-numbers are implemented in many literatures, from theoretical point of view, this approach is not certified completely. There are few structure based on the theoretical concept of Z-numbers (Gardashova, 2014). Aliev, Alizadeh, and Huseynov (2015) gave an inception, which results in the extension of the Z-numbers. Kang, Wei, et al. (2012) proposed a theorem to transfer the Z-numbers to the usual fuzzy sets. In Zadeh (2006) a novel approach was followed for the conversion of Z-number into age old fuzzy number.

Normal fuzzy equations contain fuzzy numbers just on one side of the equation. Nevertheless, dual fuzzy equations contain fuzzy numbers on both sides of the equation. Whereas the fuzzy numbers are not able to move between the sides of the equation (Kajani, Asady, & Venchech, 2005), dual fuzzy equations can be considered to be more general and complicated.

In this paper, we use dual fuzzy equations (Waziri & Majid, 2012) to model the uncertain nonlinear systems, where the coefficients are Z-numbers and the Z-numbers are on both sides of the equation. The Z-number is a novel idea that is subjected to a higher potential in order to illustrate the information of the human being as well as to use in information processing (Zadeh, 2006). Z-numbers can be regarded as to answer questions and carry out the decisions (Kang et al., 2012).

This paper is one of the first attempts in finding the solution of dual fuzzy equations based on Z-numbers. We first discuss the existence of the solutions of the dual fuzzy equations. It corresponds to controllability problem of the fuzzy control (Chen, 1994). After that, we use two types of neural networks, feed-forward and feedback networks, to approximate the solutions (control actions) of the dual fuzzy equation. At the end several examples are utilized in order to demonstrate the affectivity of our fuzzy control design methods.

2. Nonlinear System Modeling with Dual Fuzzy Equations and Z-numbers

In order to utilize dual fuzzy equations and Z-numbers, we first introduce some concepts of discrete-time nonlinear system and Z-numbers. A general discrete-time nonlinear system can be described as

$$y_k = \Psi[y_{k-1}^T, y_{k-2}^T, \dots, u_k^T, u_{k-1}^T, \dots] \quad (1)$$

where $\Psi(\cdot)$ is a nonlinear difference equation exhibiting the plant dynamics, u_k and y_k are computable scalar input and output respectively, d is noted to be time delay. The nonlinear system, which is represented by (2), is implied as a NARMA model. The input of the system with incorporated nonlinearity is considered to be as

$$x_k = [y_{k-1}^T, y_{k-2}^T, \dots, u_k^T, u_{k-1}^T, \dots]^T \quad (2)$$

Taking into consideration the nonlinear systems as mentioned in (2), it can be simplified as the following linear-in-parameter model

$$z_k = \sum_{i=1}^n a_i f_i(x_k) \quad (3)$$

Or

$$z_k + \sum_{i=1}^m b_i g_i(x_k) = \sum_{i=1}^n a_i f_i(x_k) \quad (4)$$

Here a_i and b_i are considered to be the linear parameters, $f_i(x_k)$ and $g_i(x_k)$ are nonlinear functions. The variables related to these functions are quantifying input and output. A popular example of this pattern of model is considered to be a robot manipulator (Spong & Vidyasagar, 1989)

$$M(p) \ddot{p} + C(p, \dot{p}) \dot{p} + B\dot{p} + g(p) = \tau \quad (5)$$

(5) can be explained as

$$\sum_{i=1}^n Y_i(p, \dot{p}, \ddot{p}) \theta_i = \tau \quad (6)$$

The modeling of uncertain nonlinear systems can be achieved by utilizing the linear-in-parameter models linked to fuzzy parameters. We assume the model of the nonlinear systems (3) and (4) have uncertainties in the parameters a_i and b_i . These uncertainties are in the sense of Z-numbers (Zadeh, 2011).

Definition 1: A fuzzy number A is a function $A \in E : \mathfrak{R} \rightarrow [0, 1]$ in such a way, (1) A is normal, (there prevail $x_0 \in \mathfrak{R}$ in such a way $A(x_0) = 1$); (2) A is convex, $A(\lambda x + (1 - \lambda)y) \geq \min\{A(x), A(y)\}$, $\forall x, y \in \mathfrak{R}, \forall \lambda \in [0, 1]$, 3) A is upper semi-continuous on \mathfrak{R} , i.e., $A(x) \leq A(x_0) + \varepsilon$, $\forall x \in N(x_0)$, $\forall x_0 \in \mathfrak{R}, \forall \varepsilon > 0$, $N(x_0)$ is a neighbourhood, 4) The set $A^+ = \{x \in \mathfrak{R}, A(x) > 0\}$ is compact.

Definition 2: A Z-number has two components; $Z = [A(x), p]$. The primary component $A(x)$ is termed as a restriction on a real-valued uncertain variable x . The secondary component p is a measure of reliability of A . p can be reliability, strength of belief, probability or possibility. When $A(x)$ is a fuzzy number and p is the probability distribution of x the Z-number is defined as Z^+ -number. When both $A(x)$ and p are fuzzy numbers, the Z-number is defined as Z-number.

The Z^+ -number carries more information than the Z-number. In this paper, we use the definition of Z^+ -number, i.e., $Z = [A, p]$, A is a fuzzy number, p is a probability distribution.

In order to demonstrate the fuzzy numbers, the membership functions are utilized. The most widely discussed membership functions are noted to be the triangular function

$$\mu_A = F(a, b, c) = \begin{cases} \frac{x-a}{b-a} & a \leq x \leq b \\ \frac{c-x}{c-b} & b \leq x \leq c \\ 0 & \text{otherwise } \mu_A = 0 \end{cases} \quad (7)$$

As well as trapezoidal function

$$\mu_A = F(a, b, c, d) = \begin{cases} \frac{x-a}{b-a} & a \leq x \leq b \\ \frac{d-x}{d-c} & c \leq x \leq d \\ 1 & b \leq x \leq c \\ 0 & \text{otherwise } \mu_A = 0 \end{cases} \quad (8)$$

The probability measure is expressed as

$$P = \int_R \mu_A(x)p(x)dx \quad (9)$$

Where p is the probability density of x and R is the restriction on p . For discrete Z-numbers, we have

$$P(A) = \sum_{i=1}^n \mu_A(x_i)p(x_i) \quad (10)$$

The space of discrete fuzzy sets is denoted by \tilde{E} . $\tilde{E}_{[a,b]}$ denotes the space of discrete fuzzy sets of $[a, b] \subset R$. Signifying \hat{Z} the space of discrete Z-numbers as

$$\hat{Z} = \{Z = (A, p) | A \in \tilde{E}, p \in \tilde{E}_{[0,1]}\} \quad (11)$$

Definition 3: The α -level associated to a fuzzy number A is stated as

$$[A]^\alpha = \{x \in \mathfrak{R} : A(x) \geq \alpha\} \quad (12)$$

also, $0 < \alpha \leq 1$. Or

$$[A]^\alpha = (\underline{A}^\alpha, \bar{A}^\alpha)$$

In order to operate the Z-number, we propose the following definition.

Definition 4: The α -level of the Z-number $Z = (A, p)$ is demonstrated as

$$[Z]^\alpha = ([A]^\alpha, [p]^\alpha) \quad (13)$$

Where $0 < \alpha \leq 1$. $[p]^\alpha$ is calculated by the Nguyen's theorem

$$[p]^\alpha = p([A]^\alpha) = p([\underline{A}^\alpha, \bar{A}^\alpha]) = [\underline{P}^\alpha, \bar{P}^\alpha]$$

Where $p([A]^\alpha) = \{p(x) | x \in [A]^\alpha\}$. So $[Z]^\alpha$ can be expressed as the form α -level of a fuzzy number

$$[Z]^\alpha = (\underline{Z}^\alpha, \bar{Z}^\alpha) = ((\underline{A}^\alpha, \underline{P}^\alpha), (\bar{A}^\alpha, \bar{P}^\alpha)) \quad (14)$$

Where $\underline{P}^\alpha = \underline{A}^\alpha p(\underline{x}_i^\alpha)$, $\bar{P}^\alpha = \bar{A}^\alpha p(\bar{x}_i^\alpha)$, $[x_i]^\alpha = (\underline{x}_i^\alpha, \bar{x}_i^\alpha)$.

Similarly with the fuzzy numbers (Jafari & Yu, 2015), the Z-numbers are also incorporated with four primary operations; \oplus , \ominus , \odot and \oslash . These operations are exhibited by; sum, subtract, multiply and division. The operations in this paper are different from that mentioned in (Zadeh, 2011). The α -level of Z-numbers is applied to simplify the operations.

Let us consider $Z_1 = (A_1, p_1)$ and $Z_2 = (A_2, p_2)$ be two discrete Z-numbers illustrating the uncertain variables x_1 and x_2 , also $\sum_{k=1}^n p_1(x_{1k}) = 1$ and $\sum_{k=1}^n p_2(x_{2k}) = 1$. The operations are defined as

$$Z_{12} = Z_1 * Z_2 = (A_1 * A_2, p_1 * p_2)$$

where $* \in \{\oplus, \ominus, \odot, \oslash\}$.

The operations for the fuzzy numbers are defined as (Jafari & Yu, 2015)

$$\begin{aligned} [A_1 \oplus A_2]^\alpha &= [A_1^\alpha + A_2^\alpha, \bar{A}_1^\alpha + \bar{A}_2^\alpha] \\ [A_1 \ominus A_2]^\alpha &= [A_1^\alpha - A_2^\alpha, \bar{A}_1^\alpha - \bar{A}_2^\alpha] \\ [A_1 \odot A_2]^\alpha &= [A_1^\alpha A_2^\alpha + A_1^\alpha \bar{A}_2^\alpha - A_1^\alpha \bar{A}_2^\alpha + \bar{A}_1^\alpha \bar{A}_2^\alpha - \bar{A}_1^\alpha A_2^\alpha] \end{aligned} \quad (15)$$

For all $p_1 * p_2$ operations, we use convolutions for the discrete probability distributions

$$p_1 * p_2 = \sum_i p_1(x_{1,i})p_2(x_{2,(n-i)}) = p_{12}(x)$$

The above definitions satisfy the Hukuhara difference (Aliev, Pedryczb, et al. 2016)

$$Z_1 \ominus_H Z_2 = Z_{12}$$

$$Z_1 = Z_2 \oplus Z_{12}$$

Here if $Z_1 \ominus_H Z_2$ prevail, the α -level is

$$[Z_1 \ominus_H Z_2]^\alpha = [Z_1^\alpha - Z_2^\alpha, \bar{Z}_1^\alpha - \bar{Z}_2^\alpha]$$

Obviously, $Z_1 \ominus_H Z_1 = 0$, $Z_1 \ominus Z_1 \neq 0$.

If A is a triangle function, the absolute value of the Z-number $Z = (A, p)$ is

$$|Z(x)| = (|a_1| + |b_1| + |c_1|, p(|a_2| + |b_2| + |c_2|)) \quad (16)$$

Now we utilize fuzzy equations (3) or (4) to model the uncertain nonlinear system (2). The parameters of the fuzzy Equations (3) or (4) are in the form of Z-numbers

$$y_k = a_1 \odot f_1(x_k) \oplus a_2 \odot f_2(x_k) \oplus \dots \oplus a_n \odot f_n(x_k) \quad (17)$$

or

$$\begin{aligned} a_1 \odot f_1(x_k) \oplus a_2 \odot f_2(x_k) \oplus \dots \oplus a_n \odot f_n(x_k) \\ = b_1 \odot g_1(x_k) \oplus b_2 \odot g_2(x_k) \oplus \dots \oplus b_m \odot g_m(x_k) \oplus y_k \end{aligned} \quad (18)$$

where a_i and b_i are Z-numbers. (18) is considered to be more general as compared to (17), it is termed as dual fuzzy equation.

Taking into consideration a particular case, $f_i(x_k)$ has polynomial pattern,

$$(a_1 \odot x_k) \oplus \dots \oplus (a_n \odot x_k^n) = (b_1 \odot x_k) \oplus \dots \oplus (b_n \odot x_k^n) \oplus y_k \quad (19)$$

(19) is termed as dual polynomial based on Z-number.

The main intention associated with the modeling is to diminish error in midst of two output y_k and z_k . As y_k is noted as a Z-number and z_k is considered to be crisp Z-number, hence we apply the minimum of every points as the model mentioned below

$$\begin{aligned} \max_k |y_k - z_k| &= \max_k |\beta_k| \\ y_k &= ((u_1(k), u_2(k), u_3(k)), p(v_1(k), v_2(k), v_3(k))) \\ \beta_k &= ((\rho_1(k), \rho_2(k), \rho_3(k)), p(\phi_1(k), \phi_2(k), \phi_3(k))) \end{aligned} \quad (20)$$

By the definition of absolute value (abs), we conclude

$$\begin{aligned}
\max_K |\beta_k| &= \max_K (|u_1(k) - f(x_k)| + |u_2(k) - f(x_k)| \\
&+ |u_3(k) - f(x_k)|, (|p(v_1(k)) - f(x_k)| + |p(v_2(k)) - f(x_k)| + |p(v_3(k)) - f(x_k)|)) \\
\rho_1(k) &= \max_K |u_1(k) - f(x_k)|, \quad \rho_2(k) = \max_K |u_2(k) - f(x_k)|, \\
\rho_3(k) &= \max_K |u_3(k) - f(x_k)| \\
p(\phi_1(k)) &= \max_K |p(v_1(k)) - f(x_k)|, \quad p(\phi_2(k)) = \max_K |p(v_2(k)) - f(x_k)|, \\
p(\phi_3(k)) &= \max_K |p(v_3(k)) - f(x_k)|
\end{aligned} \tag{21}$$

The modelling constraint (20) is to uncover $u_1(k)$, $u_2(k)$, $u_3(k)$, $p(v_1(k))$, $p(v_2(k))$ and $p(v_3(k))$ in such a manner

$$\min_{u_i(k), p(v_i(k))} \left\{ \max_k |\beta_k| \right\} = \min_{u_i(k), p(v_i(k))} \left\{ \max_k |y_k - f(x_k)| \right\}, \quad i = 1, 2, 3 \tag{22}$$

Considering (21), we have

$$\begin{aligned}
\rho_1(k) &\geq |u_1(k) - f(x_k)|, \quad \rho_2(k) \geq |u_2(k) - f(x_k)|, \\
\rho_3(k) &\geq |u_3(k) - f(x_k)| \\
p(\phi_1(k)) &\geq |p(v_1(k)) - f(x_k)|, \quad p(\phi_2(k)) \geq |p(v_2(k)) - f(x_k)| \\
p(\phi_3(k)) &\geq |p(v_3(k)) - f(x_k)|
\end{aligned}$$

(22) can be resolved by the application of linear programming methodology

$$\left\{ \begin{array}{l} \text{subject:} \\ \text{subject:} \end{array} \right. \left\{ \begin{array}{l} \min \rho_1(k) \\ \rho_1(k) + \left\{ \sum_{j=0}^n a_j \odot x_k^j \right\} \ominus_H \left(\sum_{j=0}^n b_j \odot x_k^j \right) \geq f(x_k) \\ \rho_1(k) - \left\{ \sum_{j=0}^n a_j \odot x_k^j \right\} \ominus_H \left(\sum_{j=0}^n b_j \odot x_k^j \right) \geq -f(x_k) \\ \min \varphi_1(k) \\ p(\varphi_1(k)) + \left\{ \sum_{j=0}^n a_j \odot x_k^j \right\} \ominus_H \left(\sum_{j=0}^n b_j \odot x_k^j \right) \geq f(x_k) \\ p(\varphi_1(k)) - \left\{ \sum_{j=0}^n a_j \odot x_k^j \right\} \ominus_H \left(\sum_{j=0}^n b_j \odot x_k^j \right) \geq -f(x_k) \end{array} \right. \tag{23}$$

$$\left\{ \begin{array}{l} \text{subject:} \\ \text{subject:} \end{array} \right. \left\{ \begin{array}{l} \min \rho_2(k) \\ \rho_2(k) - \left[\sum_{j=0}^n \underline{a}_j x_k^j - \sum_{j=0}^n \bar{b}_j x_k^j \right] \geq f(x_k) \\ \rho_2(k) \geq 0 \\ \min \phi_2(k) \\ p(\phi_2(k)) - \left[\sum_{j=0}^n \underline{a}_j x_k^j - \sum_{j=0}^n \bar{b}_j x_k^j \right] \geq f(x_k) \\ p(\phi_2(k)) \geq 0 \end{array} \right. \tag{24}$$

$$\left\{ \begin{array}{l} \text{subject:} \\ \text{subject:} \end{array} \right. \left\{ \begin{array}{l} \min \rho_3(k) \\ \rho_3(k) - \left[\sum_{j=0}^n \bar{a}_j x_k^j - \sum_{j=0}^n \underline{b}_j x_k^j \right] \geq f(x_k) \\ \rho_3(k) \geq 0 \\ \min \phi_3(k) \\ p(\phi_3(k)) - \left[\sum_{j=0}^n \bar{a}_j x_k^j - \sum_{j=0}^n \underline{b}_j x_k^j \right] \geq f(x_k) \\ p(\phi_3(k)) \geq 0 \end{array} \right. \tag{25}$$

Here and explained as mentioned in (13). Henceforth, the superior way of approximating at the juncture is. The minimization of the approximation error, which is termed as is achieved.

The process involved in order to design the controller is to obtain in such a manner that the output related to the plant y_k can approach to the desired output y_k^* , or the trajectory tracking error diminishes

$$\min_{u_k} \|y_k - y_k^*\| \tag{26}$$

This control entity can be regarded as to detect a solution u_k for the following dual equation on the basis of Z-number

$$\begin{aligned}
(a_1 \odot f_1(x_k)) \oplus (a_2 \odot f_2(x_k)) \oplus \dots \oplus (a_n \odot f_n(x_k)) = \\
(b_1 \odot g_1(x_k)) \oplus (b_2 \odot g_2(x_k)) \oplus \dots \oplus (b_m \odot g_m(x_k)) \oplus y_k^*
\end{aligned} \tag{27}$$

Where $x_k = [y_{k-1}^T, y_{k-2}^T, \dots, u_k^T, u_{k-1}^T, \dots]^T$.

It is not possible to acquire an analytical solution for (27). Here, neural networks are utilized to approximate the solution (control). In order to fit the neural networks, (27) is written as

$$\begin{aligned}
(a_1 \odot f_1(x)) \oplus \dots \oplus (a_n \odot f_n(x)) \\
\times \ominus_H (b_1 \odot g_1(x)) \ominus_H \dots \ominus_H (b_m \odot g_m(x)) = y_k^*
\end{aligned} \tag{28}$$

We use feed-forward neural networks to approximate the solution of (28), see Figure 1. The Z-numbers a_i and b_i represents the inputs of the neural network, the Z-number y_k represents the output. $y_k f_j(x)$ and $y_k g_j(x)$ are the Z-number weights.

The main idea is to detect appropriate weights of neural networks in such a manner that the output of the neural network approaches the desired output y_k^* . From the view point of control, it is utter necessity to find out a suitable controller u_k , which is a function of x , in such a manner that the plant (1) (crisp value) estimates the Z-number y_k^* . In the control point

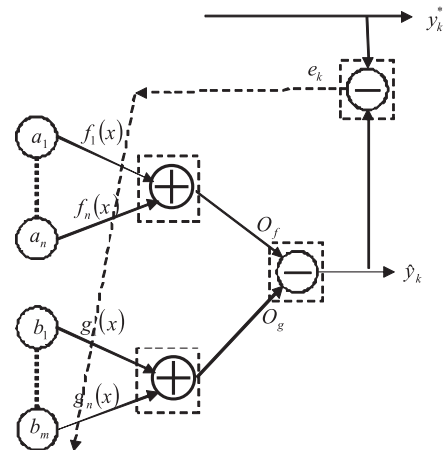

Figure 1. A Feed-forward Neural Network (NN) Approximates the Solutions of Fuzzy Equation.

of view, we want to find a controller uk , which is a function of x , such that the output of the plant (1) y_k (crisp value) approximates the Z-number y_k^* . The input Z-numbers a_i and b_i are primarily implemented to α -level as (13)

$$\begin{aligned} [a_i]^\alpha &= (\underline{a}_i^\alpha, \bar{a}_i^\alpha) \quad i = 1 \dots n \\ [b_j]^\alpha &= (\underline{b}_j^\alpha, \bar{b}_j^\alpha) \quad j = 1 \dots m \end{aligned} \quad (29)$$

The next step is initiated by multiplying the above relations with the Z-number weights $f_i(x)$ and $g_j(x)$ and summarized as

$$\begin{aligned} [O_f]^\alpha &= \left(\sum_{i \in M_f} f_i^\alpha(x) \underline{a}_i^\alpha + \sum_{i \in C_f} f_i^\alpha(x) \bar{a}_i^\alpha, \right. \\ &\quad \left. \sum_{i \in M_f'} \bar{f}_i^\alpha(x) \bar{a}_i^\alpha, \sum_{i \in C_f'} \bar{f}_i^\alpha(x) \underline{a}_i^\alpha \right) \\ [O_g]^\alpha &= \left(\sum_{j \in M_g} g_j^\alpha(x) \underline{b}_j^\alpha + \sum_{j \in C_g} g_j^\alpha(x) \bar{b}_j^\alpha, \right. \\ &\quad \left. \sum_{j \in M_g'} \bar{g}_j^\alpha(x) \bar{b}_j^\alpha, \sum_{j \in C_g'} \bar{g}_j^\alpha(x) \underline{b}_j^\alpha \right) \end{aligned} \quad (30)$$

Here $M_f = \{i | f_i^\alpha(x) \geq 0\}$, $C_f = \{i | f_i^\alpha(x) < 0\}$,
 $M_f' = \{i | \bar{f}_i^\alpha(x) \geq 0\}$, $C_f' = \{i | \bar{f}_i^\alpha(x) < 0\}$, $M_g = \{j | g_j^\alpha(x) \geq 0\}$,
 $C_g = \{j | g_j^\alpha(x) < 0\}$, $M_g' = \{j | \bar{g}_j^\alpha(x) \geq 0\}$, $C_g' = \{j | \bar{g}_j^\alpha(x) < 0\}$.

The neural network output is

$$[\hat{y}_k]^\alpha = (\underline{O}_f^\alpha - \underline{O}_g^\alpha, \bar{O}_f^\alpha - \bar{O}_g^\alpha) \quad (31)$$

The error of the training is

$$e_k = y_k^* \ominus \hat{y}_k$$

here $[y_k^*]^\alpha = (\underline{y}_k^*, \bar{y}_k^*)$, $[\hat{y}_k]^\alpha = (\underline{\hat{y}}_k, \bar{\hat{y}}_k)$, $[e_k]^\alpha = (\underline{e}_k, \bar{e}_k)$.

A cost function, which is generated on the basis of Z-numbers is implemented for the training of the weights as mentioned below

$$J_k = \underline{J}^\alpha + \bar{J}^\alpha, \quad \underline{J}^\alpha = \frac{1}{2} (\underline{y}_k^* - \underline{y}_k^\alpha)^2, \quad \bar{J}^\alpha = \frac{1}{2} (\bar{y}_k^* - \bar{y}_k^\alpha)^2 \quad (32)$$

It is quite obvious, $J_k \rightarrow 0$ when $[\hat{y}_k]^\alpha \rightarrow [y_k^*]^\alpha$. The vital positiveness lies within the least mean square (46) is that it has a self-correcting feature that makes it suitable to function for arbitrarily vast duration without shifting from its constraints. The mentioned gradient algorithm is subjected to cumulative series of errors and is convenient for long runs in absence of an additional error rectification procedure.

$\frac{\partial J_k}{\partial x_0}$ can be calculated the same as above. The gradient technique is now utilized to train the Z-number weights $f_i(x)$ and $g_j(x)$. The solution x_0 is the function of $f_i(x)$ and $g_j(x)$. The solution x_0 is upgraded as

$$\begin{aligned} \underline{x}_0(k+1) &= \underline{x}_0(k) - \eta \frac{\partial J_k}{\partial \underline{x}_0} \\ \bar{x}_0(k+1) &= \bar{x}_0(k) - \eta \frac{\partial J_k}{\partial \bar{x}_0} \end{aligned}$$

Here η is the rate of the training $\eta > 0$.

For the requirement of increasing the training process, the adding of the momentum term is mentioned as

$$\begin{aligned} \underline{x}_0(k+1) &= \underline{x}_0(k) - \eta \frac{\partial J_k}{\partial \underline{x}_0} + \gamma [\underline{x}_0(k) - \underline{x}_0(k-1)] \\ \bar{x}_0(k+1) &= \bar{x}_0(k) - \eta \frac{\partial J_k}{\partial \bar{x}_0} + \gamma [\bar{x}_0(k) - \bar{x}_0(k-1)] \end{aligned}$$

Here $\gamma > 0$. After the updating of x_0 , it is necessary to substitute it to the weights $f_i(x_0)$ and $g_j(x_0)$. The solution related to the dual equation (27) can also be estimated by feedback neural network, as Figure 2. In this case, the inputs are the nonlinear Z-number functions $f_i(x)$ and $g_j(x)$, the concerned weights are taken to be as Z-numbers a_i and b_j . The training error e_k has been utilized here in order to update x . Once the nonlinear operations $f_i(x)$ and $g_j(x)$ are performed, O_f and O_g are considered to be similar to (44). The output related to the neural network is taken as similar to (45).

3. Simulations

In this section, we use one application to show how to use the fuzzy equation with Z-number to design the fuzzy controller.

The insulating materials center is considered to be the source of heat. The material widths are not precise and hence they suffice the trapezoidal function (8),

$$\begin{aligned} A &= [(0.131, 0.153, 0.164, 0.197), p(0.7, 0.83, 0.9)] = a_1 \\ B &= [(0.084, 0.105, 0.210, 0.527), p(0.8, 0.9, 1)] = a_2 \\ C &= [(0.096, 0.107, 0.214, 0.428), p(0.7, 0.87, 0.9)] = b_1 \\ D &= [(0.021, 0.032, 0.054, 0.086), p(0.8, 0.85, 0.92)] = b_2 \end{aligned}$$

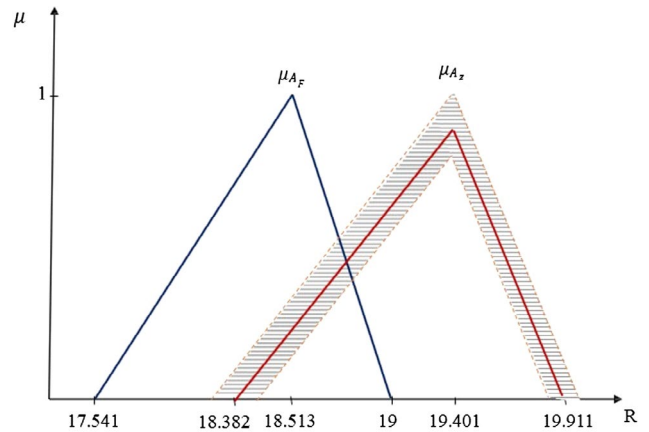

Figure 2. Z-number and Fuzzy Number.

Table 1. Neural Networks Approximate the Z-numbers.

k	x(k) with NN	k	x(k) with FNN
1	[(5.97,6.98,7.93,9.98),p(0.6, 0.8,0.85)]	1	[(5.98,6.99,7.97,9.98),p(0.7,0.85,0.87)]
2	[(5.43,6.38,7.35,9.302),p(0.7 5,0.8,0.9)]	2	[(5.37,6.10,7.12,9.16),p(0.7,0.85,0.87)]
61	[(2.11,3.170,4.22,6.33),p(0.8,0.9,1)]	45	[(2.08,3.14,4.14,6.29),p(0.8,0.96,1)]
62	[(2.06,3.08,4.11,6.17),p(0.8,0.94,1)]	46	[(2.05,3.08,4.11,6.16),p(0.8,0.94,1)]

Table 2. Neural Networks Approximate the Fuzzy Numbers.

k	x(k) with NN	k	x(k) with FNN
1	(5.13,5.99,6.841,8.576)	1	(5.36,6.25,7.14,8.939)
2	(4.93,5.79,6.671,8.440)	2	(4.81,5.46,6.37,8.199)
61	(2.00,3.00,4.007,6.008)	45	(1.99,3.00,3.95,6.004)
62	(1.96,2.934,3.915,5.870)	46	(1.95,2.93,3.90,5.864)

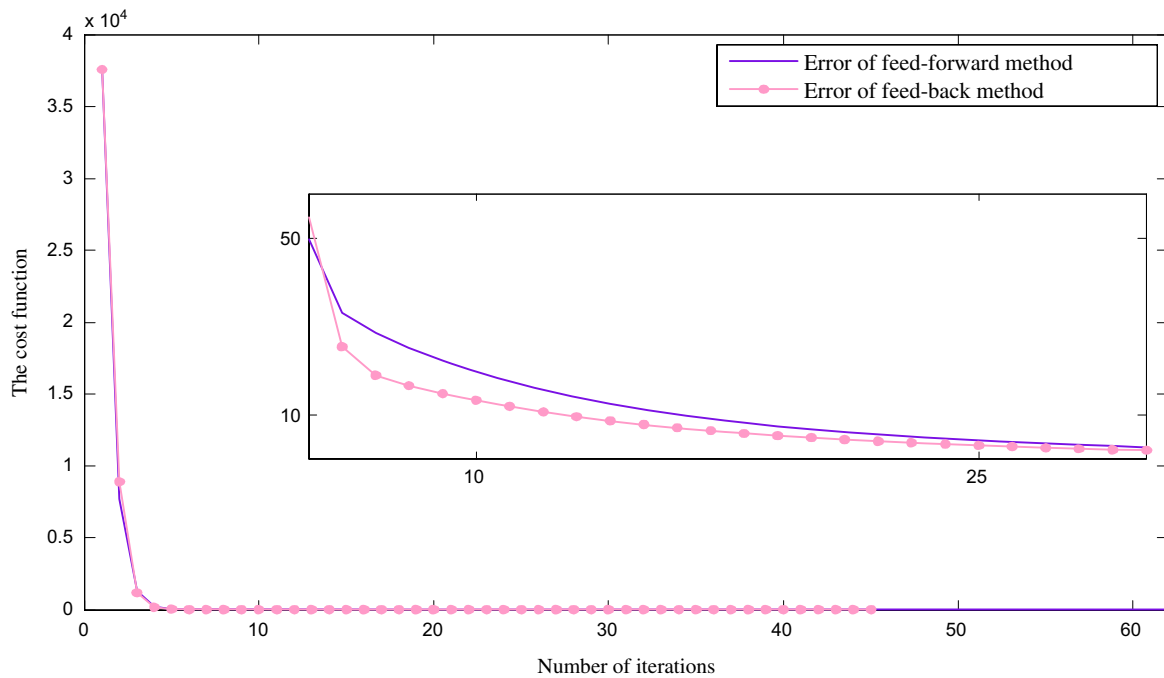

Figure 3. Approximation Errors of Neural Networks.

See Figure 2. The coefficient associated with conductivity materials are $K_A = x = f_1$, $K_B = x\sqrt{x} = f_2$, $K_C = x^2 = g_1$, $K_D = \sqrt{x} = g_2$, where x is considered to be as the elapsed time. The control object is to reveal the time in case the thermal resistance at the right side attains $R = [(0.0162, 0.0293, 0.0424, 0.1241), p(0.75, 0.8, 0.9)] = y^*$. The thermal balance model is (Holman, 1997):

$$\frac{A}{K_A} \oplus \frac{B}{K_B} = \frac{C}{K_C} \oplus \frac{D}{K_D} \oplus R$$

The exact solution is $x^* = [2.0519, 3.0779, 4.1039, 6.1559], p(0.8, 0.95, 1)]$ (Holman, 1997). The learning rate is $\eta = 0.1$ (NN) and $\eta = 0.005$ (FNN). The neural networks approximation results are displayed in Tables 1 and 2. The modeling errors are displayed in Figure 3.

4. Conclusions

In this paper, the classical fuzzy equation is modified such that its coefficients are Z-numbers. The dual type of this fuzzy model is applied to model uncertain nonlinear systems. We give the relation between the solution of the fuzzy equations and the nonlinear system control. The controllability of the fuzzy system is proposed. Two types of neural networks are applied to approximate the solutions of the fuzzy equations. Modified gradient descent algorithms are used to train the neural networks. The novel methods are validated by several benchmark examples. The future works are the application of the mentioned methodologies for fuzzy differential equations.

Disclosure statement

No potential conflict of interest was reported by the authors.

Notes on contributors



Raheleh Jafari received a B.S. degree from Islamic Azad in Shabesta, Iran in 2003 and an M.S. degree in Applied Mathematics from Islamic Azad in Arak, in 2010. Now, she is studying at the Departamento de Control Automático, CINVESTAV-IPN (National Polytechnic Institute) for her Ph.D. degree. Her research interests include fuzzy logic, fuzzy equation, neural networks, and nonlinear system modeling.



Wen Yu received a B.S. degree from Tsinghua University, Beijing, China in 1990 and M.S. and Ph.D. degrees, both in Electrical Engineering, from Northeastern University, Shenyang, China, in 1992 and 1995, respectively. Since 1996, he has been with the National Polytechnic Institute (CINVESTAV-IPN), Mexico City, Mexico, where he is currently a professor and department chair of the Automatic Control Department. He serves as associate editors of IEEE Transactions on Cybernetics, Neurocomputing, and Journal of Intelligent and Fuzzy Systems. He is a member of the Mexican Academy of Sciences.



Xiaou Li received a B.S. and Ph.D. degree in Applied Mathematics and Electrical Engineering from Northeastern University, China, in 1991 and 1995. From 1995 to 1997, she was a lecturer of Electrical Engineering at the Department of Automatic Control of Northeastern University, China. From 1998 to 1999, she was an associate professor of Computer Science at Centro de Instrumentos-UNAM. Since 2000, she has been a professor of Computer Science at Sección de Computación, Departamento de Ingeniería Eléctrica, CINVESTAV-IPN, México.

References

- Abbasbandy, S. (2006). The application of homotopy analysis method to nonlinear equations arising in heat transfer. *Physics Letters A*, 360, 109–113.

- Abbasbandy, S., & Ezzati, R. (2006). Newton's method for solving a system of fuzzy nonlinear equations. *Appl Math Comput*, 175, 1189–1199.
- Agarwal, R.P., Lakshmikantham, V., & Nieto, J.J. (2010). On the concept of solution for fractional differential equations with uncertainty. *Nonlinear Analysis: Theory, Methods & Applications*, 72, 2859–2862.
- Aliev, R.A., Alizadeh, A.V., & Huseynov, O.H. (2015). The arithmetic of discrete Z-numbers. *Information Sciences*, 290, 134–155.
- Aliev, R.A., Pedryczb, W., Kreinovich, V., & Huseynov, O.H. (2016). The general theory of decisions. *Information Sciences*, 327, 125–148.
- Allahviranloo, T., Ahmady, N., & Ahmady, E. (2007). Numerical solution of fuzzy differential equations by predictor-corrector method. *Information Sciences*, 177, 1633–1647.
- Allahviranloo, T., Otadi, M., & Mosleh, M. (2007). Iterative method for fuzzy equations. *Soft Computing*, 12, 935–939.
- Allahviranloo, T., Kiani, N., & Barkhor-dari, A.M. (2009). Toward the existence and uniqueness of solution of second-order fuzzy differential equations. *Information Sciences*, 179, 1207–1215.
- Arshad, S., & Lupulescu, V. (2011). On the fractional differential equations with uncertainty. *Nonlinear Analysis: Theory, Methods & Applications*, 74, 3685–3693.
- Buckley, J., & Eslami, E. (1997). Neural net solutions to fuzzy problems: The quadratic equation. *Fuzzy Sets and Systems*, 86, 289–298.
- Buckley, J.J., & Feuring, T. (2001). Fuzzy initial value problem for nth-order linear differential equations. *Fuzzy Sets and Systems*, 121, 247–255.
- Buckley, J.J., & Qu, Y. (1990). Solving linear and quadratic fuzzy equations. *Fuzzy Sets Syst.*, 35, 43–59.
- Chen, S.M. (1994). Fuzzy system reliability analysis using fuzzy number arithmetic operations. *Fuzzy Sets and Systems*, 64, 31–38.
- Cybenko, G. (1989). Approximation by superposition of sigmoidal activation function. *Mathematics of Control, Signals, and Systems*, 2, 303–314.
- Feng, G. (2006). A survey on analysis and design of model-based fuzzy control systems. *IEEE Transactions on Fuzzy Systems*, 14, 676–697.
- Friedman, M., Ming, M., & Kandel, A. (1998). Fuzzy linear systems. *Fuzzy Sets and Systems*, 96, 201–209.
- Gardashova, L.A. (2014). Application of operational approaches to solving decision making problem using z-numbers, *Applied Mathematics*, 05, 1323–1334.
- Goetschel, R., & Voxman, W. (1986). Elementary calculus. *Fuzzy Sets and Systems*, 18, 31–43.
- Hawrra, F., & Amal, K.H. (2013). On fuzzy Laplace transform for fuzzy differential equations of the third order. *Journal of Kerbala University*, 11, 251–256.
- Holman, J.P. (1997). *Heat transfer* (8th ed.). New York, NY: McGraw-Hill.
- Hüllermeier, E. (1997). An approach to modeling and simulation of uncertain dynamical systems. *International Journal of Uncertainty, Fuzziness and Knowledge-Based Systems*, 05, 117–137.
- Jafari, R., & Yu, W. (2015). Fuzzy control for uncertainty nonlinear systems with dual fuzzy equations. *Journal of Intelligent and Fuzzy Systems*, 29, 1229–1240.
- Jafarian, A., & Jafari, R. (2012). Approximate solutions of dual fuzzy polynomials by feed-back neural networks. *J. Soft Comput. Appl*, 2012, 1–5.
- Jafarian, A., & Measoomynia, S. (2011). Solving fuzzy polynomials using neural nets with a new learning algorithm. *Appl. Math. Sci.*, 5, 2295–2301.
- Jafarian, A., Jafari, R., Khalili, A., & Baleanu, D. (2015). Solving fully fuzzy polynomials using feed-back neural networks. *International Journal of Computer Mathematics*, 92, 742–755.
- Jafarian, A., Jafari, R., Mohamed Al Qurashi M., & Baleanu, D. (2016). A novel computational approach to approximate fuzzy interpolation polynomials, *SpringerPlus*, 5:1084
- Kajani, M., Asady, B., & Vencheh, A. (2005). An iterative method for solving dual fuzzy nonlinear equations. *Appl. Math. Comput*, 167, 316–323.
- Kang, B., Wei, D., Li, Y., & Deng, Y. (2012). A method of converting Z-number to classical fuzzy number. *Journal of Information and Computational Science*, 9, 703–709.
- Khastan, A., Nieto, J.J., & Rodríguez-López, R. (2013). Periodic boundary value problems for first-order linear differential equations with uncertainty under generalized differentiability. *Information Sciences*, 222, 544–558.
- Lupulescu, V. (2009). On a class of fuzzy functional differential equations. *Fuzzy Sets and Systems*, 160, 1547–1562.
- Mamdani, E.H. (1976). Application of fuzzy algorithms for control of simple dynamic plant. *IEE Proceedings - Control Theory and Applications*, 121, 1585–1588.
- Mazandarani, M., & Kamyad, A.V. (2013). Modified fractional Euler method for solving Fuzzy fractional initial value problem. *Communications in Nonlinear Science and Numerical Simulation*, 18, 12–21.
- Mosleh, M. (2013). Evaluation of fully fuzzy matrix equations by fuzzy neural network. *Applied Mathematical Modelling*, 37, 6364–6376.
- Pederson, S., & Sambandham, M. (2008). The Runge-Kutta method for hybrid fuzzy differential equation. *Nonlinear Analysis: Hybrid Systems*, 2, 626–634.
- Salahshour, S., Allahviranloo, T., & Abbasbandy, S. (2012). Solving fuzzy fractional differential equations by fuzzy Laplace transforms. *Communications in Nonlinear Science and Numerical Simulation*, 17, 1372–1381.
- Spong, M.W., & Vidyasagar, M. (1989). *Robot dynamics and control*. Hoboken, NJ, USA: John Wiley and Sons
- Tahavvor, A., & Yaghoubi, M. (2012). Analysis of natural convection from a column of cold horizontal cylinders using Artificial Neural Network. *Applied Mathematical Modelling*, 36, 3176–3188.
- Takagi, T., & Sugeno, M. (1985). Fuzzy identification of systems and its applications to modeling and control. *IEEE Transactions on Systems, Man, and Cybernetics*, 15, 116–132.
- Tapaswini, S., & Chakraverty, S. (2014). Euler-based new solution method for fuzzy initial value problems. *International Journal of Artificial Intelligence and Soft Computing*, 4, 58–79.
- Wang, H., & Liu, Y. (2011). Existence results for fuzzy integral equations of fractional order. *Int. J. Math. Anal*, 5, 811–818.
- Waziri, M., & Majid, Z. (2012). A new approach for solving dual fuzzy nonlinear equations using Broyden's and Newton's methods. *Advances in Fuzzy Systems*, 2012, Article 682087, 5, 2012, 1–16.
- Yu, W., & Li, X. (2004). Fuzzy identification using Fuzzy neural networks with stable learning algorithms. *IEEE Transactions on Fuzzy Systems*, 12, 411–420.
- Zadeh, L.A. (2005). Toward a generalized theory of uncertainty (GTU) an outline. *Information Sciences*, 172, 1–40.
- Zadeh, L.A. (2006). Generalized theory of uncertainty (GTU)—principal concepts and ideas. *Computational Statistics and Data Analysis*, 51, 15–46.
- Zadeh, L.A. (2011). A note on Z-numbers. *Information Sciences*, 181, 2923–2932.